

# AN INTEGRAL THEORY AND ITS METHOD FOR THE DIAGNOSIS AND MANAGEMENT OF FEMALE URINARY INCONTINENCE

PETER E PAPA PETROS

ULF I ULMSTEN

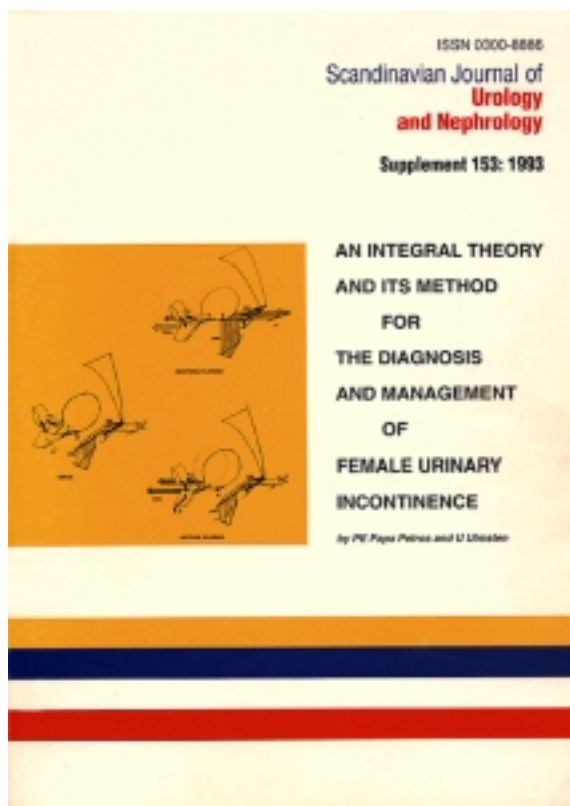

**P.E. PAPA PETROS Dr Med Sc MRCOG FRACOG**

Department of Gynaecology  
Royal Perth Hospital  
Perth, Western Australia  
Department of Obstetrics and Gynaecology  
Uppsala University  
Akademiska sjukhuset  
Uppsala, Sweden.

**U. ULMSTEN M. D. Ph.D.**

Department of Obstetrics and Gynaecology  
Uppsala University  
Akademiska sjukhuset  
Uppsala, Sweden.

Copyright © 1993 by  
the Scandinavian Journal of Urology and Nephrology

Supported by research grants from  
Swedish Medical Council No.s 8310 and 3495  
Goran Gustaffson's Foundation  
and Royal Perth Hospital

ISSN No. 0300-8886

## CONTENTS

Foreword .....	4
Part I: Theory, morphology, radiographic correlations and clinical perspective .....	5
Part II: The biomechanics of vaginal tissue, and supporting ligaments with special relevance to the pathogenesis of female urinary incontinence. ....	29
Part III: Surgical principles deriving from the theory .....	41
Appendix A - Questionnaire .....	50
Part IV: Surgical applications of the theory .....	53
An anatomical basis for success and failure of female incontinence surgery .....	55
The development of the intravaginal slingplasty procedure: IVS II - (with bilateral "tucks") .....	61
Further development of the intravaginal slingplasty procedure: IVS III - (with midline "tuck") .....	69
Further development of the intravaginal slingplasty procedure: IVS IV - (with "double-breasted" unattached vaginal flap repair and "free" vaginal tapes). ....	73
Further development of the intravaginal slingplasty procedure: IVS V - (with "double-breasted" unattached vaginal flap repair and permanent sling). ....	77
The intravaginal slingplasty procedure: IVS VI - (further development of the "double-breasted" vaginal flap repair - attached flap). ....	81
The free graft procedure for cure of the tethered vagina syndrome. ....	85
The posterior fornix syndrome: A multiple symptom complex of pelvic pain and abnormal urinary symptoms deriving from laxity in the posterior fornix of vagina. ....	89

## ACKNOWLEDGEMENTS

We would like to thank Ms Carol Yelas and Ms Marie Lindström, and also, the Depts of Radiology and Medical Illustration Royal Perth Hospital, for their assistance with preparation of the text and figures of the manuscript. We are also indebted to Dr Kate Creed, Professors Per Johnson, Anders Malmström, Anders Mattiasson, to Dr Richard Fox, Ed Skull, David Guy from the Dept of Medical Physics and Bioengineering, Royal Perth Hospital, for fruitful discussions and invaluable advice and to Professor Stig Colleen for editorial assistance.

The investigations were supported by grants from the Swedish Medical Research Council, No 8310 and No 3495, from Göran Gustafssons Foundation and from the Medical Faculty, Uppsala University and Royal Perth Hospital.

## 5FOREWORD

It is now almost 3 years since we presented our Integral Theory of Female Urinary Incontinence (1). Since that time we have had the opportunity to challenge the concepts originally presented, not only by further morphological and urodynamic studies, but in a clinical sense also, by direct application of the theory to each of the hundreds of patients we have treated in that time. This has led to many of the concepts being further refined and clarified. In the present work, many of the muscle movements predicted by the theory have been identified using levator myograms, barium studies, EMG and pressure studies. We introduce a new concept for dynamic pressure measurements in the urethra and bladder, whereby pressure transmission ratio reflects directly the contractile force of the pelvic floor, and indirectly, specific defects in the vagina or its supporting ligaments.

### Style of Expression

In this work, we have attempted to fulfil the criteria of Karl Popper as concerns expression and exposition of a theory. Therefore the Integral Theory has been deliberately expressed in a small number of explicit statements. This fulfils a prime obligation of any theory, that it must be testable for truth or falsity. This obligation has forced us to make many definitive statements on matters which have not been properly tested. This may reasonably irritate some readers. As medical scientists, we fully acknowledge this criticism. The alternative, however, would be to express the theory in a way which precludes proper testing of the theory. Explicit statements allow deductive methods of proof to be applied, and predictions to be made. This not only permits the theory itself to be tested by particular experiments, *but it also places an obligation on the theory to explain the large body of data already in existence. According to Popper, no theory can ever be finally proven.* In this context, this work can only be regarded as a small step in what we foresee will be a new perspective on female urinary incontinence.

### Practical information and guidelines for reading this supplement.

This supplement is divided into four parts.

Part I gives an introduction of the integral theory on female urinary incontinence. Morphological, radiographic and urodynamic evidence is presented for the suggested mechanisms. The clinical perspective is given through six identified anatomical defects which also comprise a new classification for diagnosis and treatment of female urinary incontinence. Although somewhat detailed, this part constitutes a basic platform for the three sections which follow.

Part II aims to outline how the biochemical changes inherent in connective tissue affect the biomechanical properties of the vagina and its supporting ligaments, and how these in turn impact on functional and dysfunctional opening and closure of urethra and bladder neck.

Part III outlines briefly the surgical principles deriving from the integral theory as described in the two previous sections.

Part IV gives some direct surgical applications of the theory, based on parts I-III and also, our previous experimental work for treatment of female urinary incontinence (1). **Because the ultimate perspective of this work is therapeutic, we suggest that it may be useful to begin at section IV, and to work back at the reader's convenience.**

PE PAPA PETROS AND U ULMSTEN

(1) A detailed account of the original theory, its surgical applications, and various supporting clinical papers is available in Acta Scand O&G, Vol 69 Supplementum, No 153, 1990, 1-79. For the reader's convenience, exact page numbers are given along with this reference.

## PART I: THEORETICAL, MORPHOLOGICAL, RADIOGRAPHICAL CORRELATIONS AND CLINICAL PERSPECTIVE

PE PAPA PETROS Dr Med Sc MRCOG FRACOG and U ULMSTEN MD PhD

**ABSTRACT** The Integral Theory on Female Urinary Incontinence states: stress symptoms, urge symptoms, and symptoms of defective flow may all derive, for different reasons, from laxity in the suburethral vagina or its supporting ligaments. This theory proposes that the pre-tensioned anterior vaginal wall transmits specific pelvic muscle contractions which open or close the bladder neck and urethra. The vagina is tensioned like the membrane of a drum against the ligaments which support it from above. In its tensioned state, the vagina can be pulled by the pelvic floor muscles to mechanically open or close bladder neck. The tensioned vagina also indirectly supports the nerve terminals at bladder base. Vaginal laxity may predispose to premature activation of the micturition reflex. If this reflex cannot be suppressed, then the subsequent uninhibited detrusor contraction may cause urinary urge incontinence (bladder instability). Therefore, laxity\* in the vaginal tissue or its supporting ligaments may, for different reasons cause symptoms of stress incontinence, urge incontinence, or of defective opening.

Based on the evidence presented here and in previous studies (1), a new anatomical classification of female urinary incontinence can be made, consisting of six specific anatomical defects. Characteristic clinical, morphological and urodynamic changes which help to diagnose a particular defect are identified, as is the modifying effect of age, hormones, and iatrogenically induced scar tissue. Three separate closure mechanisms are described, urethral, bladder neck, and a separate voluntary mechanism.

\* excessive tightness of these structures may also cause dysfunction of the opening/closure mechanisms in the patient who has been already subjected to surgical interference.

Key words: Theory; Urinary Incontinence; Connective Tissue; Biomechanics; Pelvic Floor; Surgery.

### Review of existing theories of stress incontinence.

It is a traditional concept in medicine, that dysfunction may be due to anatomical defects, and that function comes with restoration of anatomy. This has led to the identification of various morphological defects as causative factors for stress urinary incontinence (SI). These include the posterior urethrovesical angle (2), inclination of the urethral axis (3), (4), length of urethra (5) the relationship of urethrovesical junction to the most dependent part of bladder (6), flatness of the base plate (7), and anterior and posterior radiological defects of bladder base (8), pubourethral ligament (9) (10), paravaginal and other fascial defects, (11) (12). Due to a wide overlapping in the findings of continent and stress incontinent females,

these morphological defects have been shown to bear little relationship to the existence of SI in a particular patient (13).

The most commonly accepted theory today (13) is the intra-abdominal pressure equalization theory, (14). And yet major inconsistencies have been present in this theory for a long time, FIG 1.

As early as 1954, Bailey (3) described his type 2B incontinence, whereby the bladder neck was situated high above the inferior border of pubic symphysis, with no significant rotation or descent on straining. Using simultaneous urethrocystometry, Constantinou (15) demonstrated that on coughing, the urethral pressure rise preceded the bladder pressure rise. No correlation was found between the position of the

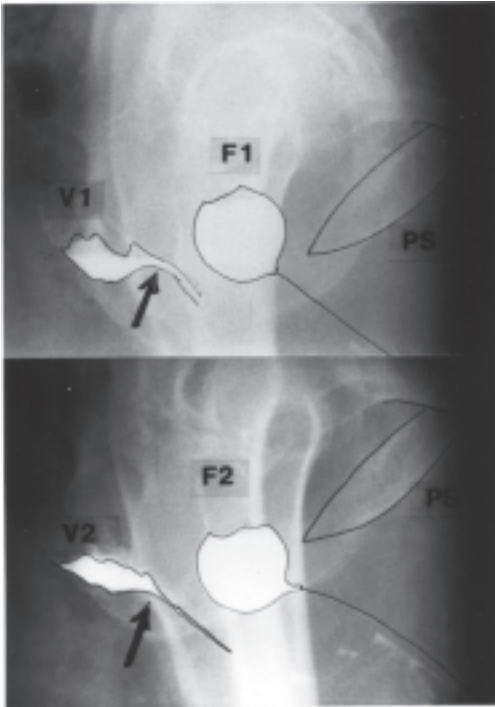

FIG 1

**Inadequacy of pressure equalization theory.**

F = Foley balloon; V = vagina; 1 = resting position; 2 = straining position.

*If the intraabdominal pressure equalization theory were to be correct, a midurethral cough transmission ratio of 91% such as was registered in FIG 1 would be an impossibility, as virtually the whole urethra is situated below the pubic bone.*

bladder neck relative to the inferior border of pubic symphysis, and urinary incontinence, (16). The principal reason why the pressure equalization theory still seems to have currency, is that patients with stress incontinence are frequently cured by bladder neck elevation surgery. However, bladder neck elevation is not a pre-requisite for cure of SI. Vaginal repair (17), which does not elevate the bladder neck, may cure SI in more than 50% of cases. Cure of SI (without bladder neck elevation) has been demonstrated by correction of the 6 specific anatomical defects (1), (p53-79). Included in this group were many patients whose bladder neck remained below the inferior border of pubic symphysis (1), (p57) after cure.

**Historical basis for the theory of detrusor instability.**

The entity presently called “detrusor instability”, ICS (18) is not new. It has existed in one form or other at least since 1905, being variously called ‘active incontinence’, ‘uninhibited’ or ‘hypertonic’ bladder, ‘unstable bladder’, Bates (19). An indirect reference to this was made already in 1887 by Guyon (20) “Cystite Douloureuse”.

The early physiologists related the sensations of bladder filling to the afferent nerves running from the bladder to the spinal cord and the efferent nerves running from the spinal cord to the bladder, Barrington (21), Fernsides (22). Fernsides described complete and incomplete interferences with the power of holding urine both on the effector side and on the afferent side. Included in these were local interference. It was a simple matter, then, to impute the occurrence of bladder instability to abnormalities in this circuit. During cystometric studies carried out by Rose (23) and Parker and Rose (24), characteristic patterns were observed, similar to those found with neurological lesions. Included in this category were patients with senility or “insufficient cerebrum” on the efferent side and unspecified “local” lesions on the afferent side.

Denny-Brown (25) observed the detrusor’s tendency to spontaneous all or none contraction “the process of storage of urine and its evacuation occurs therefore in a reservoir of which the distension excites a tendency to an automatic discharge”.

Denny-Brown in 1933 measured urethral and bladder pressures simultaneously. He demonstrated that in the normal patient the involuntary micturition initiated by bladder filling could be controlled voluntarily. Most authors, however, were unwilling to allow possibility of any direct voluntary control over smooth muscle though some authors in particular, Rehfish (26) Adler (27) & Le Gros Clarke (28) believed that voluntary control was possible. Muller (29) suggested that the afferent impulse arose in the voluntary external sphincter so that any effort to micturate would affect the bladder indirectly.

Denny-Brown agreed that a proprioceptive afferent stimulus for the reflex e.g. arising from the muscles themselves was difficult to exclude. Voluntary suppression of the vesical activity was "absolute and unequivocal". A reciprocal relationship was noted between urethral relaxation and detrusor contraction, i.e. the internal sphincter relaxed when the bladder contracted.

Lapides (30) also described the "uninhibited neurogenic bladder" in a group of patients who had no evidence of neurological disturbance with symptoms of urgency, frequency and precipitate micturition. He attributed such disturbances to incomplete development of cerebral integration much as occurs in a young child. It was described as dyssynergic detrusor dysfunction, Hodgkinson (31) psychogenic bladder, Youssef (32), an uninhibited bladder by Ingelman-Sundberg (33).

In more than 1000 combined cine/pressure/flow studies, Bates et al (19), it was objectively demonstrated that many patients who lost urine on coughing also initiated a detrusor contraction, and that coughing could stimulate detrusor contraction *per se*. Of patients with recurrent symptoms of incontinence after surgery, more than 2/3 were found to have unstable bladders. An unspecified number of patients with preoperatively unstable bladders showed no improvement in symptoms after repair operation. Bates (19) claimed that the distinction between stress and urge incontinence may be difficult or impossible on the symptoms and examination alone, i.e. the history of leakage on rising from a chair or walking may be particularly difficult to interpret when not associated with urgency. The purpose therefore of objective studies was to isolate that group of patients unlikely to respond to surgery who had bladder instability. This viewpoint has been reinforced by most investigators (34-39). Not all studies indicate low surgical success rate with pre-existing detrusor instability. A high success rate was demonstrated with incontinence surgery in patients with pre-existing detrusor instability (40,41).

Thus most investigators unequivocally accepted that bladder instability as diagnosed urodynamically was

the prime pathogenic disturbance with symptoms correlating at best, less than 50%, (42-47).

The diagnostic process of filling cystometry was not without its critics, however. Some (48) counselled caution because at best urodynamics created an artificial situation because of the fast fill process.

The concept of bladder instability was further refined by the various committees of the International Continence Society 1976 (49) The term "detrusor instability" was introduced to describe a detrusor which was objectively demonstrated to contract spontaneously in a phasic pattern on provocation during the filling phase while the patient was attempting to inhibit micturition.

There are many problems associated with assessment of a patient (50), a principal one being that symptoms mean different things to different people, with wide individual variation. Urodynamics offered hope for the future as it was a scientific physiological method which was analytical and therefore could overcome the "label system" inherent in a symptomatic approach (50). In particular biology needed mathematical rationalization to become a true science (50). In summary, the concept of "detrusor instability" has evolved into a clinical entity, endowed with mathematical precision. It is commonplace for all symptoms and signs relevant to bladder instability to be compared against the gold standard of "detrusor instability", and to be invalidated if there is a conflict with this standard. "Detrusor instability" has, however, never been formally tested as a theory.

According to (1) however, urge symptoms, "urethral instability", "detrusor instability", and actual urine loss may all be mainly different manifestations of a prematurely activated micturition reflex. Using a urethrocystometric technique (51), 78% of 115 patients with a prior history of urge incontinence presenting with a full bladder and subjected to a handwashing test, were noted to experience one or both of the following: fall in urethral pressure, and followed some seconds later by a rise in detrusor pressure, exactly as occurs in normal micturition

(52) (53). It was also recently demonstrated (54) by direct observation in 77 patients who lost urine with a hand-washing provocation test, that if the patient reported urge symptoms in association with urine loss, the patient's testimony (history of urge incontinence) was likely to be more than 95% reliable. Using other manifestations of the micturition reflex, such as urine loss, or urge symptoms as the gold standard, it was concluded that the urodynamic process itself appeared to be defective, not the symptomatology. The reason may lie in what cystometry is attempting to measure, an end point of a complex chaotically determined biological process.

### **The chaotic nature of biological systems.**

"The entire scientific enterprise represents a search for algorithmic compressions of data (55). These are often represented by theories or laws". In a physical system, they can be determined mathematically.

Natural systems (this would include such terms as detrusor instability), however, cannot be algorithmically compressed (55), and tend to be chaotic, and therefore not given to linear mathematical derivation (56). Some familiar examples include turbulent fluids, fibrillating hearts, dripping taps etc.

Urine retention or loss by the bladder is a complex process. Barrington (21) described 5 reflexes concerned with the initiation of micturition alone. Since then a plethora of initiatory and inhibitory centres have been demonstrated in the cerebral cortex, pons, medulla, cerebellum, midbrain, basal ganglia and hypothalamus, Fenely (57). Added to this must be the impact of the urethral, bladder neck and voluntary closure mechanism (1), with all their component individual reflexes, the impact again on these by the 6 anatomical defects (appendix A) the effect of multiple hormones, patients' moods and psychological and even mental states (58) etc. *According to the Chaos Theory, each of the factors described, no matter how small, has the capacity to make an impact on the process of urine retention/expulsion, and therefore, depending on the interaction of each and every component factor with another, actually change the end result.* This explains how, for example in pad testing, there is poor repeatability of results in the

individual patient, but, a better correlation within the group. This can be attributed to the greater number of symptoms assessed (76a). Similarly, taking the premature activation of the micturition reflex as being the ultimate cause of both urge symptoms and "detrusor instability"(54), the diagnostic efficiency of urge symptoms is necessarily much higher than a one-off reading on a machine, given that the latter is being compared with the collective memory of the patient (76a).

In summary then, the chaotic nature of the urinary control system would appear to preclude precise mathematical assessment by a linear system such as cystometric testing (76a). Also, if, as appears to be so, involuntary urine loss caused by detrusor contraction may be mainly a premature activation of the micturition reflex, then the necessity for cystometric testing for detrusor instability, must also be questioned (76a), especially as the patient's history of urge incontinence is likely to be accurate (54).

### **The present status of the pressure equalization and "detrusor instability" theories.**

"Scientific theories are universal statements"(59). Using such universal laws, it is possible to give a causal explanation, and predict singular events. Ideally a theory should be simply expressed, consistent and falsifiable. Though it is a self obvious assertion that a theory which contains an internal contradiction is invalid, nevertheless, we frequently work with statements, which, though actually false, nevertheless yield results which are adequate for certain purposes", Popper (59). Popper proposes two rules of methodology:

1. Scientific statements can never reach a point where they can be regarded as finally verified.
2. Once a hypothesis has been proven to some degree of validity it should not be allowed to drop out without good reason i.e. unless it can be replaced by another hypothesis which is "better testable" or the falsification of one of the consequences of the hypothesis.

The two theories on which much of the present science of urogynaecology has been based, the pres-



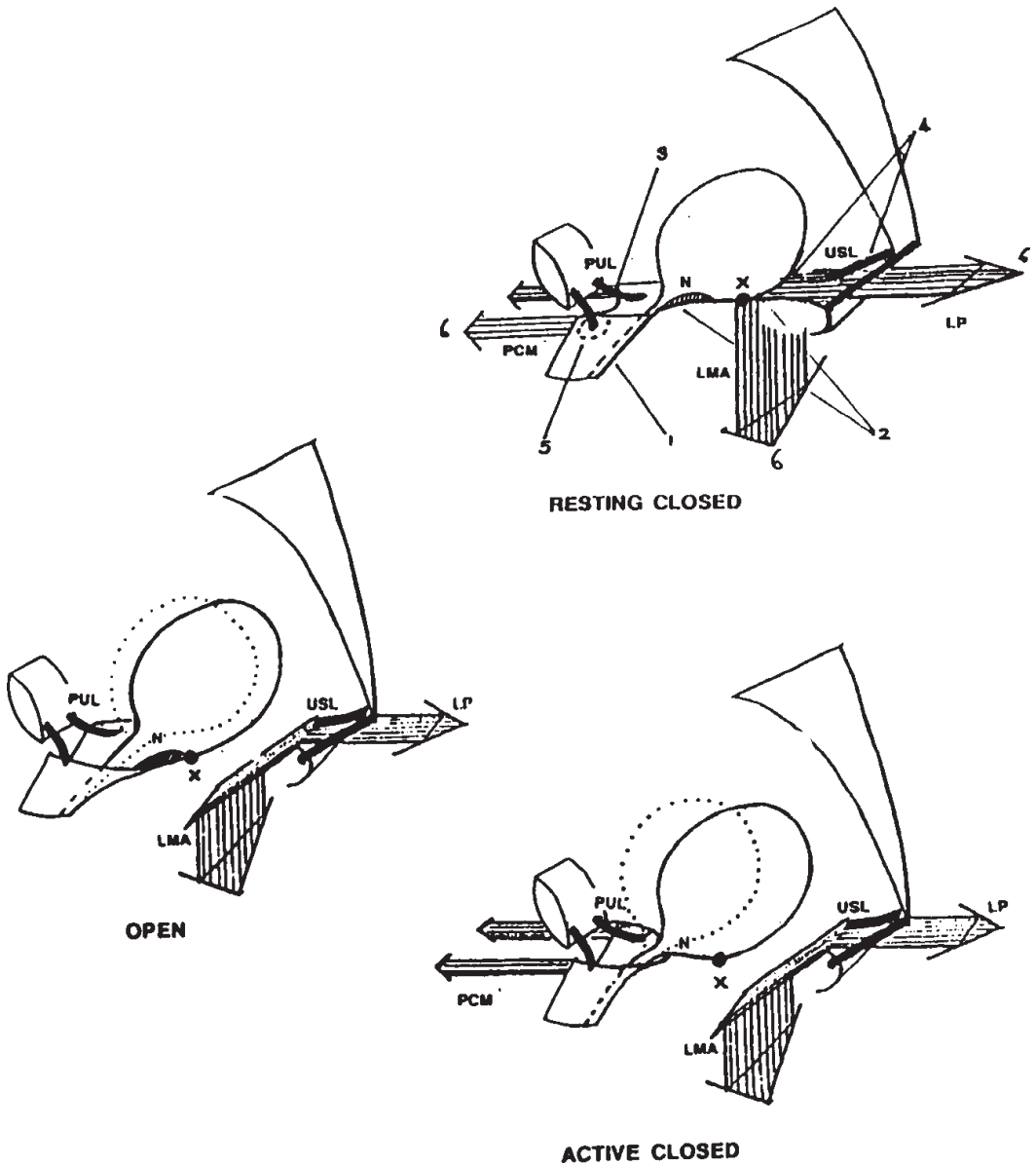

FIG 2

### Mechanisms of opening and closure the urethra/bladder neck.

This represents a sagittal section of the bladder and urethra nestled in the anterior vaginal wall. PUL = pubourethral ligament; USL = uterosacral ligament; PCM = anterior portion of the pubococcygeus muscle, LP = levator plate LMA = longitudinal muscle of the anus. The numbers signify the position at which the various anatomical defects occur, according to the classification. 1: suburethral vagina. 2: supraleator vagina. 3: pubourethral ligament. 4: uterosacral ligament. 5: collagenous insertion of the pubococcygeus muscle. 6: striated muscle damage

*In the functional sense, striated muscle requires a fixed insertion into the vagina/ligaments for efficient contraction. Laxity in the system may result in deficient closure forces being generated, so that the bladder neck remains in the "open" position.*

sure equalization theory (14), and the concept of “detrusor instability” (18) will be examined in the above context. As concerns the pressure equalization theory, (14), operative elevation of the bladder neck has been demonstrated to efficiently cure stress incontinence, so that many surgeons recommend such a procedure as the operation of choice (60). As concerns the detrusor instability theory, it has been demonstrated that bladder neck elevation surgery is associated with a high failure rate (19) (35) (36), so that urodynamic testing for this condition is regarded as essential for the diagnosis to be made, allowing alternative forms of treatment. Thus both the theories as described have validity, in that they are being effectively used as working hypotheses. *It follows that it is not sufficient to simply present evidence to invalidate an existing theory, eg FIG1. Ultimately, any challenge to the theory of “detrusor instability” (e.g. by the Integral Theory (1), has to meet the dual requirements of not only invalidating the existing theories, but also, to be able to “better explain” all the various phenomena associated with urinary incontinence.*

The new Integral Theory is presented with the specific perspective of attempting to “better explain” as many observations as possible on urinary incontinence with respect to the theory as stated below.

### **The Integral Theory of Female Urinary Incontinence**

states that: *stress symptoms, urge symptoms, and symptoms of defective flow may all derive, for different reasons, from laxity in the vagina or its supporting ligaments, a result of altered connective tissue.*

In the following, the Integral Theory will be penetrated from different aspects, starting with morphologic and physiologic considerations.

### **ANATOMY AND PHYSIOLOGY**

#### **Involuntary urethral and bladder neck closure mechanisms.**

These are separate, but linked by an elastic bridge, the “zone of critical elasticity”

**The voluntary closure mechanism** or “cutting-off” mechanism uses a different group of muscles which elevate the bladder neck. All 3 mechanisms are simultaneously demonstrated in FIG 6.

#### **ROLE OF VAGINA IN BLADDER NECK OPENING AND CLOSURE.**

*The tensioned vagina regulates opening and closure of the bladder neck.*

**“Resting closed position”.** The numbers 1-6, FIG 2 signify the position at which the various anatomical defects occur. The vagina is suspended anteriorly by the pubourethral ligament (PUL) (10), superiorly by the arcus tendinaeus fasciae pelvis, (61), and posteriorly by the uterosacral ligament (USL) (1). The vagina is tensioned like the membrane of a drum against its suspensory ligaments, by slow twitch muscle contractions of pubococcygeus muscle (PCM) anteriorly, levator plate (LP) posteriorly, and the longitudinal muscle of the anus (LMA) inferiorly. At the same time, the stretched vagina ‘supports’ the nerve endings (N) at the bladder base preventing premature activation of the micturition reflex, or “bladder instability”\*.

\* “bladder instability” is not actually defined by the ICS (18), but by convention it consists of an involuntary loss of urine in association with a detrusor contraction.

**“Active closed”.** Fast twitch contraction forward of (PCM) pulls the two ends of the ascending vagina (FIG 2) tightly around the urethra, closing it off and immobilizing it while (LP) and (LMA) pull the bladder down and back like an elastic balloon, kinking off and closing off the urethra like a hose. For these opposite muscle movements to occur there needs to be sufficient elasticity in the bladder neck area, zce, FIG 3.

**“Open position”.** As part of the micturition reflex, (PCM) relaxes. This allows (LP) and (LMA) to uninhibitedly pull at (X), opening the bladder base, creating a “funnel”, enlarging the urethral outlet (1) (P21). At the same time, this stretching stimulates the nerve endings (N), activating and reinforcing the micturition reflex, which is further re-enforced by the presence of urine in the proximal urethra (21)

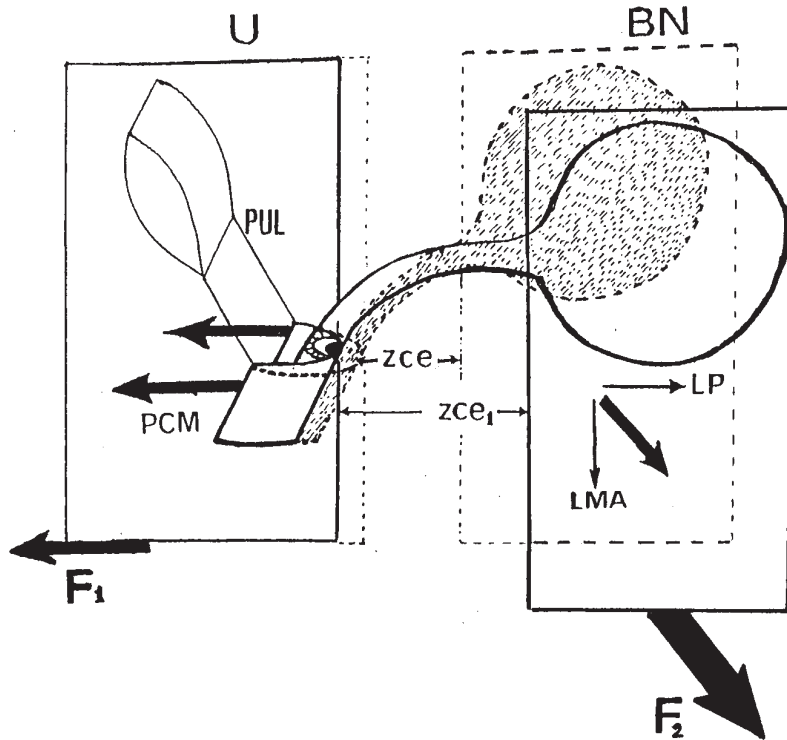

FIG 3

**Urethral and bladder neck closure mechanisms.**

U = urethral closure mechanism; BN= bladder neck closure mechanism; zce = zone of critical elasticity; zce1 = zone of critical elasticity during straining/micturition; F1= anterior force PCM = pubococcygeus muscle; F2 = postero-inferior force; LP =levator plate; LMA = longitudinal muscle of the anus. *The urethral (U) and bladder neck (BN) closure mechanisms, FIG 3, are separate and require adequate elasticity in the intervening tissues to operate efficiently.*

*In a functional sense, such elasticity must be present in zce, the "zone of critical elasticity"\*. This zone acts "like an accordion", permitting "U" and "BN" to perform their closure functions independently. There are two independent and opposite forces acting on the vagina, F1 and F2. F1 acts in the front part of vagina, and closes the urethra; F2 acts in the posterior part of vagina and closes the bladder neck. It opens bladder neck when F1 relaxes. During opening and closure, zce elongates to zce1. F1 is the weaker force and is created by forward movement of the pubococcygeus muscle. F2 is the stronger force, and is created by the vectors of levator plate (LP), and longitudinal muscle of the anus (LMA). If zce is too tight, F2 opposes F1, so that the bladder neck now opens on being given the signal to close.*

\* strictly speaking, the " zone of critical elasticity extends from the insertion of the pubo-urethral ligament (1) (p8).

## RADIOLOGICAL PROOF OF THE OPENING AND CLOSURE MECHANISMS,

as suggested in FIGS 2 & 3.

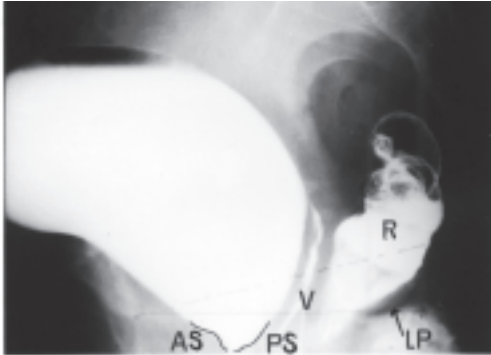

Fig 4a.

### Resting closed position

R = rectum; V = vagina; LP = levator plate, with arrow pointing to its superior border; AS = anterior bladder shelf; PS = posterior bladder shelf.

*This is a videocystourethrography of a 50 year old continent woman in the resting position. The bladder neck is situated well below the horizontal line which intersects the ano-rectal junction. The levator plate (arrow) lies almost parallel to the floor. The anterior bladder shelf AS (9), at the bladder base is well defined. The posterior bladder shelf PS (9), is visible as the posterior wall of bladder angulates forwards to join the urethra.*

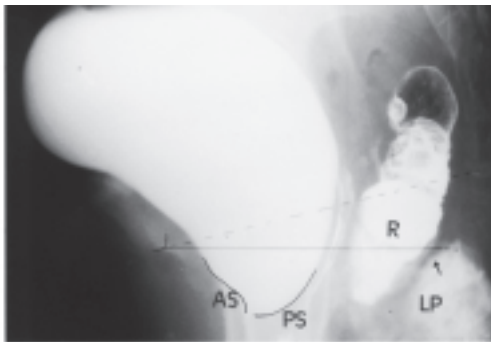

FIG 4b.

### On straining

*The anterior shelf does not alter, consistent with a tensioning effect (1) (p21), by the pubovesical ligament. The bladder base has been pulled downwards, and the posterior shelf flattened. The vagina, rectum, anorectal junction, and anterior part of levator plate (arrow) have been synchronously pulled downwards, consistent with a neuromuscular co-ordinated reflex (1) (p21).*

FIG 4c

### EMG and urodynamic correlations

U = urethral pressure; B = bladder pressure; s = straining; c = 'cut-off'

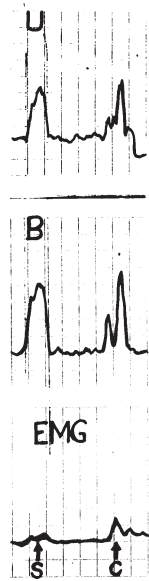

*The bladder pressures recorded during straining, FIG 4b and "cutting-off", FIG 4e, were equivalent.*

*Note that the levator plate and pelvic organs are elevated during "cutting-off" ( FIG 4e), but depressed during straining (FIG 4b). This makes the commonly held viewpoint that intra-abdominal pressure causes downward displacement of the pelvic organs unsustainable.*

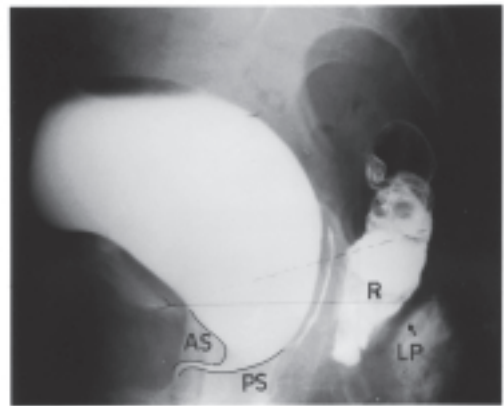

FIG 4d

### At micturition

*All the structures are in virtually identical positions as in straining (FIG 4b) as predicted (1): the almost identical descent and angulation of the superior border of the levator plate (arrow); descent of anorectal junction, bladder base, and vagina. (1) (p19). The anterior bladder shelf (AS) appears to be anchored, and of the same shape as in FIG 4b; "during bladder neck opening, exactly the same events take place as in bladder neck closure, except that the anterior portion of pubococcygeus muscle reflexly relaxes, enabling the levator plate to open proximal urethra, and to stimulate the nerve endings at bladder base, initiating the micturition reflex; (1) (p11)" and, "the active opening of bladder neck into a funnel by traction of the pelvic floor muscles on the vagina is an essential element for the expulsion of urine." (1) (p21).*

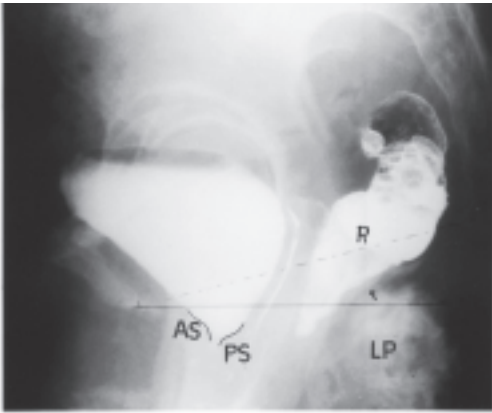

FIG 4e

**Voluntary closure mechanism (“cutting-off”)**

At “cutting off” in mid-stream (1) (p10), an acute angle returns to the posterior shelf of bladder base, the ano-rectal junction and superior border of levator ani muscle (arrow) are elevated well above the horizontal line. The vagina and bladder neck appear to have been lifted upwards and forwards, clearly different movements from straining (FIG 4b). Pressure generation is, however, equivalent (FIG 4c) .

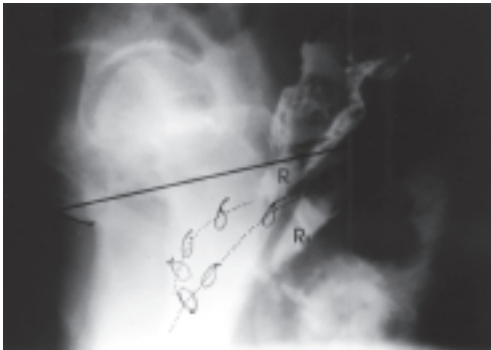

FIG 5

**Postero/inferior stretching of vagina during urination**

A standing lateral x-ray of an asymptomatic patient in the “resting closed” position is superimposed on a micturition film. Three vascular clips have been applied to the vagina, from below upwards to: midurethral area, bladder neck area, and 3-4 cm posterior to the bladder neck area. Dotted lines indicate the position of the anterior vaginal wall. R = rectum in the resting position, and R1 in the straining position. The black line joins the inferior border of pubic symphysis to the lower end of the coccyx.

The upper clip , 3-4 cm posterior to the bladder neck (equivalent to point “X” in FIG 2), is stretched

backwards. The vagina in the area of urethra and bladder neck is stretched backwards and downwards, synchronously with the rectum. The angulated shape of the anterior wall of vagina has been flattened out, (“funnelling”). That segment of vagina between the lower and upper clip corresponds approximately to “zce” (FIG3) in the resting position and “zce1” in the position of micturition.

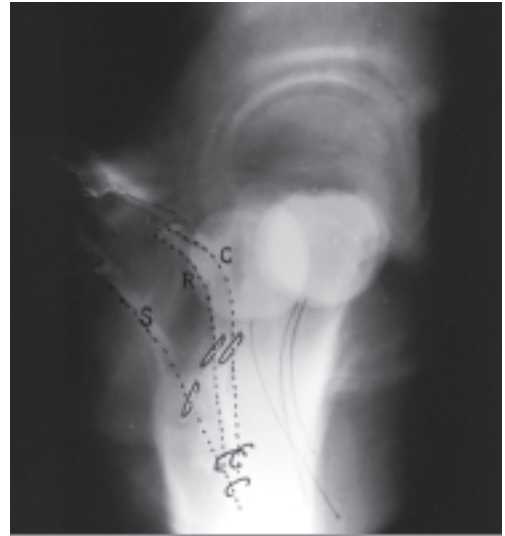

FIG 6

**Differential stretching of vagina during straining and “cutting-off”, FIG 6.**

This figure represents three superimposed standing lateral x-rays of a normal patient. The vagina, dotted lines, is shown in the “cut-off” (C), “resting closed” (R), and straining (S) positions. Vascular clips have been applied to the vagina in the midurethral and bladder neck areas. Radio-opaque dye delineates the Foley catheter balloon. During “cut-off” (C), the vagina and bladder neck are simply lifted upwards and forwards of the resting closed position (R). During “straining” (S), the upper part of vagina appears to have been stretched longitudinally backwards, and pulled downwards in the bladder neck section, (upper clip). The midurethral area of vagina, however (lower clip), is pulled downwards and forwards. The tube of the Foley catheter has also been pulled forwards in this area.

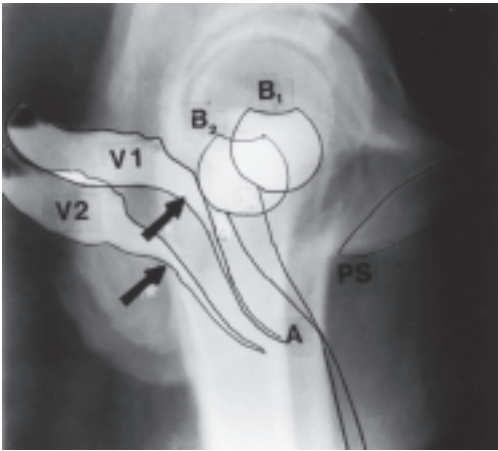

FIG 7a

#### High elasticity in vagina and PUL.

This figure represents two superimposed standing lateral x-rays of a young normal patient; B = Foley balloon positioned in bladder, V = vagina wall; 1 = resting closed position; 2 = active closed position (straining); arrows indicate the transverse sulcus of vagina in the bladder neck area. A = the presumed position of the pubo-urethral ligament's insertion into vagina.

*The whole vagina moves backwards and is angulated downwards, as is A, indicating significant elasticity in the PUL. Fulcrum point "A" is situated well below the transverse sulcus of vagina, (arrows), and therefore, bladder neck. This indicates that the correct tethering point of urethra during involuntary closure is well below the bladder neck. Surgical restoration should likewise be in this position. Comparison with FIG 5 (micturition) graphically indicates the anatomical reason why urinary retention almost invariably occurs post-operatively in patients following surgical elevation of the bladder neck. The middle and upper clips in FIG5 would be prevented from "funneling". "Visco-elastic creep" over the ensuing days/weeks rescues the situation. This gradually loosens the tissues in the bladder neck area, permitting muscular opening of the outflow channel, as in FIG 5.*

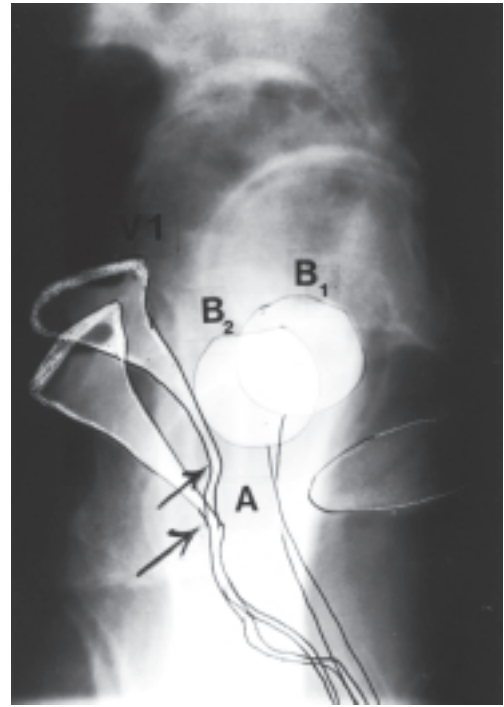

FIG 7b

#### Inelasticity of vagina and the pubourethral ligament.

This figure represents two superimposed standing lateral x-rays of a 60 year old patient with stress and urge incontinence; B = Foley balloon positioned in bladder, V = vagina wall; 1 = resting closed position; 2 = active closed position (straining); arrows indicate the transverse sulcus of vagina in the bladder neck area. A = the presumed position of the pubo-urethral ligament's insertion into vagina. *There is very little extension downwards at point A, bladder neck and vagina, indicating poor tissue elasticity. The transverse sulcus (arrows) is very close to point A, indicating minimal posterior extension of PUL. Therefore the margin between urethral fixation and over extension of vaginal tissue in the bladder neck area (zce) would be very small indeed. Such a patient is at risk of developing the "tethered vagina syndrome" with a bladder neck elevation procedure (1), as there is not the same possibility as in FIG 7a for restoration of elasticity through "visco-elastic creep" (cf part II).*

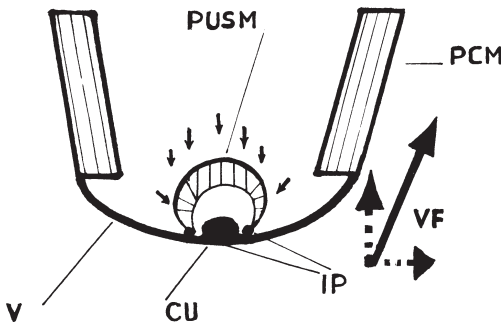

FIG 8

**Urethral closure mechanism.**

This figure represents a cross-section taken through the midurethra. V = vagina; IP = insertion points of PUSM; CU = crista urethralis; arrows = vector forces.

**CLOSURE MECHANISMS.*****Urethral Closure Mechanisms***

*Contraction of the anterior pubococcygeus muscle (PCM) closes the urethra. Contraction of the periurethral striated muscle (PUSM) provides a water-tight seal in the presence of a trophic mucosa.*

Anatomically, the urethra lies suspended in a “hammock”(1), (62), (63), (64) of vaginal epithelium as indicated in FIGS 8, 17. Contraction of the anterior portion of pubococcygeus muscle (PCM), FIG 8, pulls the crista urethralis (CU) towards the periurethral striated muscle (PUSM) by tensioning the vagina (V), at the same time anchoring the insertion (IP) of the periurethral striated muscle (PUSM).

Most of the work for closure is performed by the anterior portion of the pubococcygeus (PCM). The PUSM merely creates a water-tight seal by its action on trophic urethral mucosa. The slow twitch fibres of the (PUSM) contribute to resting urethral pressure. The (PUSM), at least in a functional sense, appears to have a fast-twitch action, as noted by needle EMG studies (62). Our data indicates (1) (33-35), FIG 10, that it is mainly this fast twitch contraction of the (PUSM) which is recorded by the pressure transducers during the cough transmission ratio (CTR) determinations. Defects 1-3, FIG 2 may affect the urethral mechanism and cause incontinence of urine. The urethral closure mechanism may maintain closure even in the presence of an incompetent bladder neck. Entry of urine into the proximal urethra has been observed on VCU without accompanying incontinence (65).

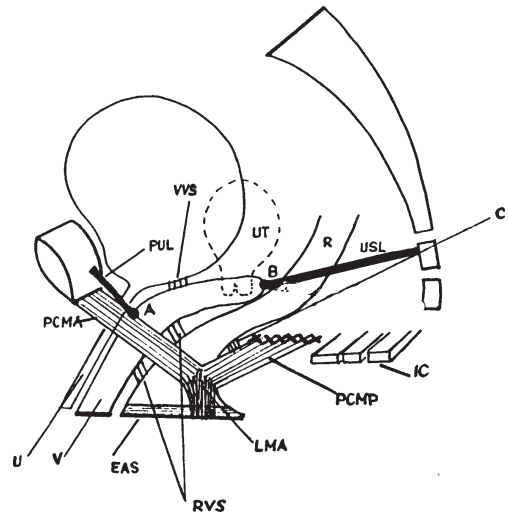

FIG 9

**Bladder neck closure mechanism**

PCMA = anterior portion of the pubococcygeus muscle; PUL = pubourethral ligament; PCMP = posterior portion of pubococcygeus muscle; IC = ilio/fischio - coccygeus muscle C = connective tissue joining the levator plate to the posterior wall of rectum, R; V = the vagina; RVS = rectovaginal septum; VVS = vesicovaginal septum ; LMA = longitudinal muscle of the anus; EAS = external anal sphincter; USL = uterosacral ligament; UT = uterus; U = urethra; A = insertion point of PUL; B = insertion point of USL.

*The essential principle of this mechanism is that the horizontal striated muscles of the pelvic floor contract, so becoming semi-rigid. These are then pulled downwards in their mid-section by contraction of the longitudinal muscle of the anus (LMA).*

***Bladder Neck Closure Mechanisms***

This downward action indirectly pulls down the bladder base, “kinking” it like a hose at the internal orifice of the immobilized urethra. The urethra is immobilized by forward contraction of the anterior portion of the pubococcygeus muscle, PCM (A). This pulls against the pubourethral ligament (PUL), which acts as a fulcrum. The levator plate comprises the

posterior portion of pubococcygeus muscle (PCMP) and ilio/ischio-coccygeus muscle (IC). It contracts and pulls the bladder base backwards against the (PUL) by pulling on rectum and vagina. This movement requires a coordinated involuntary tensioning of the fibromuscular septa and the smooth muscle of the organs themselves (1), (p21), so that they all move in concert, FIG 12b. The now semi-rigid levator plate is tilted downwards, like a trapdoor, FIG 4b, by the longitudinal muscle of the anus (LMA).

The LMA extends from the level of the levator fascia above to the perianal skin below. It draws fibres from the pubococcygeus, pubo-rectalis, and ilio-coccygeus muscles, (66), surrounds the rectum, and is inserted into the external anal sphincter (EAS), (67). Postero-laterally there exists a circum-anal space (66) which separates this muscle from the rectum. This presumably allows the LMA to pull down the levator plate without in any way compromising the rectal wall. The EAS must be pre-tensioned for efficient functioning of this mechanism. Relaxation or immobilization of PCM (A) for whatever reason, will push the system into the “bladder neck open” mode, creating a funnel, FIG 5. At the same time, intact cardinal ligaments, uterosacral ligaments, and rectovaginal septum are necessary for transmission of the (LMA) contraction to rectum, vagina and bladder. Defects 2-6, FIG 2 may affect the bladder neck closure mechanism and cause incontinence of urine.

### ***Voluntary Closure Mechanisms.***

Whereas the urethral and bladder neck closure mechanisms are interdependent and involuntary, the voluntary closure mechanism, FIGS 6 & 4e, can be radiologically and ultrasonically demonstrated to be quite different and under voluntary control. It results in elevation of the bladder base, rather than descent, and is thought to be mediated either by the lateral group of pubococcygeus muscles, or by the puborectalis, (1) (p10). In the normal patient, the desire to micturate is also controlled by the voluntary closure mechanism, which may counteract the stretching of nerve endings at bladder base by voluntary elevation of the pelvic floor, (1) (p10,29), FIG 4e. This mechanism also has the capacity to inhibit or reverse the micturition reflex, “VC” FIG 13.

## **PATHOPHYSIOLOGY**

### **Anatomical classification of female urinary incontinence according to laxity.**

The number preceding the defect corresponds to the number in FIG2. Specific clinical symptoms associated with each particular defect are summarized in Appendix A. Depending on the site of the laxity, and the “sensitivity” of the nerve endings, the patient could experience stress incontinence, urge incontinence, defective bladder neck opening\*, or various combinations of all three.

- (1) Suburethral vaginal (“hammock”) defect.
- (2) Excessive tightness/scarring in the bladder neck zone.
- (3) Loose pubourethral ligaments.
- (4) Loose uterosacral ligaments/lax supralelevator vagina.
- (5) Damaged collagenous insertion of pubococcygeus muscle into vagina.
- (6) Striated muscle damage
  - a) Trauma to external anal sphincter
  - b) Levator plate
    - torn muscle insertion to pubic bone.
    - lax collagenous insertions.
    - paralysis.

\* Given the common aetiology, defective opening should be considered as part of the same spectrum of urinary dysfunction.

In the context of this anatomical classification, the present ICS (18) classifications of “detrusor instability”, “urethral instability”, “genuine stress incontinence” etc. are considered to describe observed events.

### **How symptoms relate to the classification.**

In general, defects in the front part of the vagina are more likely to be responsible for SI, while defects in the back part of the vagina are more likely to be responsible for symptoms of defective opening, Appendix A. Symptoms of frequency, urgency, and nocturia may occur equivalently with either. Diagnosing anatomical defects 1-6 in a particular patient does not mean that she will necessarily have symptoms of incontinence. Other factors are also impor-



tant, such as the urethral pressure, which has vascular and smooth muscle components, and the ability of the various compensatory mechanisms, in particular the involuntary, and voluntary mechanisms, FIGS 4-6. The latter may be learnt, and include elevation of the pelvic floor by voluntary contraction, (pelvic floor exercise), and the inhibitory mechanisms of the brain (bladder training exercises).

### Defect 1- Suburethral vaginal defect - excessive looseness.

The symptom of “dampness throughout the day” is often due to a defective urethral closure mechanism.

*Pathogenesis and clinical diagnosis* There is observable laxity in the suburethral vaginal mucosa. Loss of urine in the supine position on coughing may be controlled by the “pinch test” (1) (p33-35), i.e. taking a small fold of vagina paraurethrally with Littlewood’s forceps, and asking the patient to cough. Urine loss controlled by this test demonstrates the importance of an adequately tight suburethral vagina for urethral closure. Many patients were able to pass urine during this “pinching”(1) pp 33-35), indicating that the mechanism as described in FIG 8 was the operative mechanism, not urethral obstruction. In the presence of an intact PUL, there may be a low transmission ratio (CTR). If the pubourethral ligament fulcrum point, PUL, FIG 2, is intact, PCM pulls against it as it would in the normal patient. Therefore any laxity in the suburethral vagina means that the insertion points IP, FIG 8, cannot be anchored. The (PUSM) cannot contract efficiently, resulting in deficient urethral closure, and low cough transmission ratio (CTR). If the PUL fulcrum point is lax, then PCM and LP can no longer contract independently against it, and therefore LP may overpower PCM due to the fact that the vagina stretches first in the longitudinal axis, FIGS 17, 17a. The result is that the insertion points, IP, are tensioned, PUSM now contracts efficiently, and so the CTR may register 100%, even though there is no urethral closure. This is explained further in the biomechanics section.

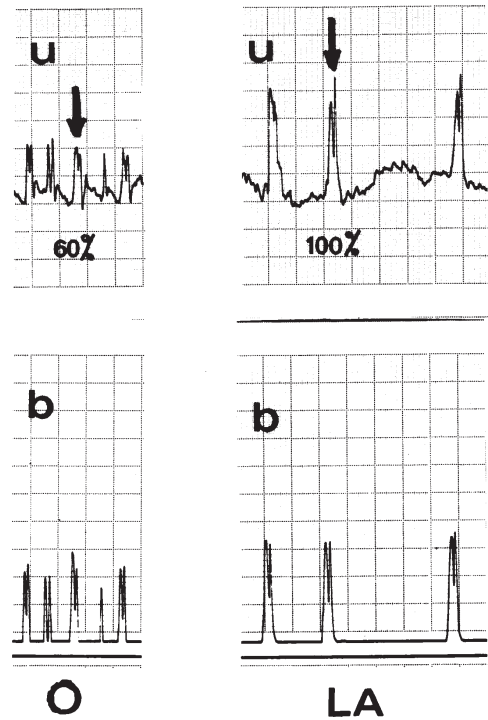

**FIG 10**  
**Effect of periurethral oedema on cough transmission ratio.**

u = urethral pressure; b = bladder pressure; O = pre-injection readings; LA = pressure readings after para and suburethral injection of a diluted local anaesthetic solution.

*This is a urethrocytometric tracing taken from a patient with SI. As seen in the figure, CTR increased from 60% to 100% after paraurethral local anaesthetic injection. According to what is said above, this may be explained by the oedema immobilizing the insertion points IP of the (PUSM)(1). The results are consistent with the concept of restoring efficient contraction, and increased urethral pressure derived from the periurethral striated muscle.*

The symptom of “dampness throughout the day” is often due to a defective urethral closure mechanism as described above, often combined with a defective mucosal seal due to an atrophic urethral mucosa and deficient vascularity causing a low maximal urethral pressure. Improvement in symptoms with oestrogen therapy can be attributed to improvement in the mucosal seal. Often such leakage can be improved by inserting a vaginal tampon. Low urethral pressure and low vaginal elasticity is diagnosed by the “slow

leak speculum sign” (1) (p66): as the examining Sim’s speculum is pushed gently but firmly into the posterior fornix of vagina, a slow steady leakage of urine is observed, relieved by taking out the speculum. Often the leakage begins even as the speculum enters the vagina. Indeed, in extreme cases, such urine loss may even be elicited by simply stretching the suburethral vaginal mucosa. Most likely, this phenomenon is due to low urethral pressure associated with deficiency or hampering of the forward urethral closure force, F1, FIG 3.

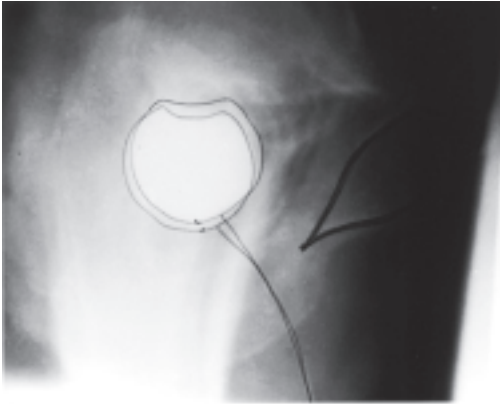

FIG 11a

**Tethered vagina syndrome - preoperative.**

*A preoperative straining x-ray has been superimposed on a resting radiograph in a patient with urinary incontinence due to the “tethered vagina syndrome” in the presence of a net deficit of tissue elasticity in the anterior vaginal wall. There is virtually no movement on straining. This condition is invariably iatrogenic.*

**Defect 2 - Excessive tightness/scarring in the bladder neck zone:**

We have described this as the “tethered vagina syndrome” (1) (p63).

Scarring or loss of elasticity in the ‘zone of critical elasticity’ (zce), of the vagina due to previous vaginal repair or bladder neck elevation surgery, may “tether” the pubococcygeus muscle (PCM) to the levator plate (LP), FIG 3. The zce in effect, acts as an inelastic connecting rod, so that F2 overpowers F1. The bladder neck opens when given the signal to close.

*Pathogenesis and clinical diagnosis.* The “tethered vagina syndrome” is often associated with a low

urethral pressure (1) (p64). Almost invariably, the patient wets prior to arrival at the toilet in the morning. In the worst cases, wetting begins just on getting out of bed. “Cutting off” is impossible. There may be no significant stress incontinence (1) (p64). Many patients complain of leakage on bending over, but without any stress incontinence on coughing, a “paradoxical leakage”, as the pressure generated on bending over is far lower than on coughing (1) (p65). ZCE, FIG 3, is inelastic. F2 represents the powerful contraction of pelvic floor needed to contain the intra-abdominal organs; F2 easily neutralises F1, and so the bladder neck opens instead of closing. On examination, the vagina is usually very tight in the region of the bladder neck. There is no “swing” of the urethrovesical junction (UVJ) on straining. Insertion of a ring pessary may worsen the incontinence. Grasping the vagina with Littlewood’s forceps just behind the urethrovesical junction and pushing backwards may sometimes induce urine loss on coughing where this symptom did not previously exist. In patients with associated low urethral pressure, the “slow leak speculum sign” (1) (p66) is often found to be positive. All these tests are based on stretching residual elasticity out of zce, FIG 3, so that F1 is prevented from closing the urethra.

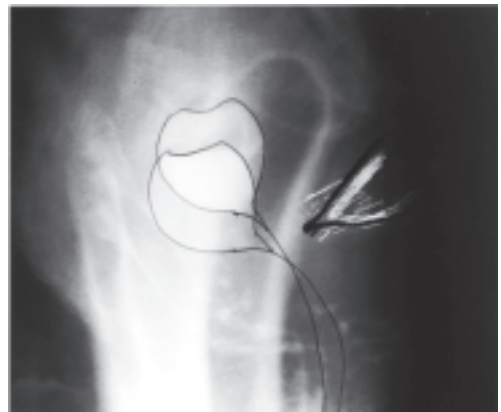

FIG 11b

**Tethered vagina syndrome - postoperative.**

*The same patient as in FIG 11a following restoration of vaginal elasticity and cure by a free graft in the bladder neck area of vagina.*

Surgical restoration of elasticity by I-plasty or free vaginal graft to the bladder neck area of anterior vaginal wall (1) (68) have, in our hands, frequently induced normal excursion downwards of bladder neck during straining and restored continence (FIG 11b). Such surgical procedures as plastic surgery using full thickness grafts require uneventful healing. Rejection of the graft usually leads to further scarring and possible worsening of symptoms.

*Forward tethering.* If the bladder neck is too tightly anchored anteriorly to the pubic symphysis during bladder neck elevation or sling procedures, creation of a funnel (FIG5) by F2 may not be possible, leading to difficulty in bladder emptying and high postoperative residual urine. Some of these patients never urinate properly again.

### Defect 3 - Pubourethral ligament defect.

*This may be the most serious defect. The important fulcrum function is lost, so that both urethral and bladder neck closure mechanisms may be inactivated.*

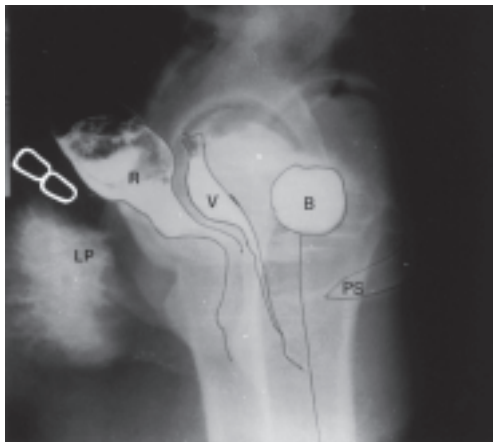

**FIG 12a**  
**Pubourethral ligament (PUL) defect - resting closed position.**

This is a standing lateral x-ray of a patient with stress incontinence; PS = pubic symphysis; structures outlined with radio-opaque dye: B = bladder; V = vagina; R = rectum; LP = levator plate.

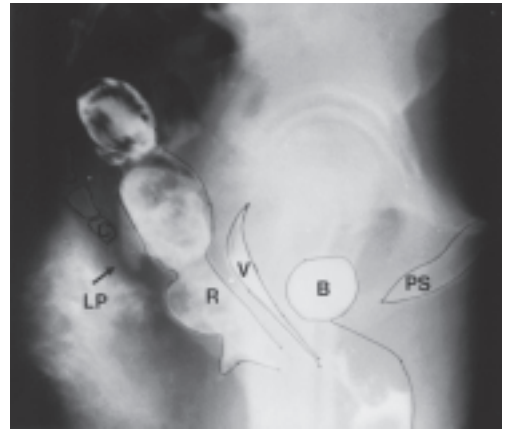

**FIG 12b**  
**Pubourethral ligament (PUL) defect - straining position.**

*Pathogenesis and clinical diagnosis.* The bladder, vagina and rectum are all in the correct anatomical position at rest FIG 12a, but fall backwards on straining, FIG 12b, prolapsing synchronously below the inferior border of pubic symphysis. Active downward angulation of levator plate appears to have caused these events. Laxity of the pubourethral ligament (PUL) may be congenital, occur due to advanced age (collagen loss), or childbirth (1), p12). Such a defect may be suspected if the patient has difficulty in opening the last part of her bowels or if there is also some faecal soiling, (unpublished observations). Our Intravaginal Sling operation performed for urinary incontinence, cured, quite by accident, 30 patients with faecal incontinence. Also more than half of our patients with urinary incontinence who also complained of difficulty in “opening the last part of their bowels”, were cured by this operation. Creation of an artificial pubourethral ligament (1), (p43-51) or collagenous reinsertion (“re-gluing”) of vagina to the pubococcygeus muscle appeared to be the relevant factor in the cure of both symptoms.

In very old patients, there may be no urge or stress urinary symptoms as such, (1) (p53). The patients may present with “dropping their urine on the floor” on getting up from a chair. With a deficient PUL, there is no fulcrum for F1 to pull against, so that F2 overpowers F1, FIG 3. The bladder neck opens on being given the signal to close.

The IVS procedure cured 20/26 very old patients (mean age 81 years) with principally urinary urge incontinence (unpublished observations). Some of these patients presented simply with “dropping their urine on the floor”, and without symptoms of urine loss on coughing. In many of these patients, tightening of the suburethral vagina was not performed, indicating that deficiency of the pubourethral ligament/collagenous insertion of vagina to muscle was probably the prime defect.

Urethroscopically, on positioning the urethroscope just distal to the closed internal urethral meatus, opening occurs on asking the patient to strain (1) (p 11). A simple classical test for pubourethral defect is the Bonney test. Unilaterally applied, it is impossible to obstruct the urethra. The Bonney test works by anchoring the urethra, much in the same way as the pubourethral ligament does (1) (p34).

#### **Defect 4 - Loose uterosacral ligaments/lax supralelevator vagina:**

This is due to laxity in the posterior fornix of vagina. The patient may have symptoms of urinary incontinence, defective emptying, pelvic pain, and high residual urine.

*Pathogenesis and clinical diagnosis.* It is likely that overdistension of the posterior fornix during labour, and transverse suturing of the vault without attention to its ligamentous supports during hysterectomy are important aetiological factors (1) (p71), though we have seen it less frequently as a congenital defect, becoming symptomatic after menarche. Laxity of the supralelevator vagina may not allow adequate tensioning of the vagina below the bladder neck nerve endings, FIG 2, resulting in symptoms of frequency, urgency nocturia. F2 is diminished. Pressure transmission ratio at the Valsalva test may be positive instead of negative, as would normally be expected in a patient with urinary incontinence (cf also FIG 22 Biomechanics section).

The patient may have symptoms of defective emptying, pelvic pain, (cf Appendix A), findings of high residual urine, and varices noted laparoscopically at the site of the uterosacral ligaments (69). On

examination there may be a bulge between the uterosacral ligaments, or presence of an early enterocele. It is possible to perform a posterior fornix “pinch test” (1) (p34) by approximating the two lateral corners of the posterior vaginal fornix in the midline. Insertion of a ring pessary may similarly tighten the posterior fornix and bring a dramatic improvement in symptoms. As such it is a useful diagnostic test.

#### **Defect 5 - Loose collagenous insertion between vagina and pubococcygeus muscle (1) (p58).**

This is also a serious defect with symptoms similar to those found in a pubo-urethral ligament defect.

*Pathogenesis and clinical diagnosis.* The vagina is inserted (“glued”) to the undersurface of pubococcygeus muscle by collagenous connective tissue. An overstretched collagenous insertion point between pubococcygeus muscle and vagina, defect no. 5, FIG 2, may alter the bladder neck closure mechanism, as the muscle belly of PCM cannot properly be tensioned against the PUL fulcrum. It may also inactivate the urethral closure mechanism.

Defect 5 - may correspond to Bailey’s type 2B defect (3) or “inferior support” defect (3), or to Richardson’s paravaginal fascial defect (11) (12). Clinically, the presentation is similar to that for PUL defect. We diagnose it by inference\* in patients whose bladder neck is radiologically in the correct anatomical position at rest and on straining, together with a loose suburethral vagina on clinical examination, in the presence of high cough transmission ratio. We have noted that many very old patients present for the first time with symptoms similar to those reported in the section on pubourethral defect, “dropping urine on the floor”, faecal incontinence, etc. Radiologically, the bladder neck is in the correct anatomical position at rest and on straining. Differential diagnosis from (PUL) defect may not be easy if the bladder neck is situated below the inferior border of the pubic symphysis at rest.

\* differentiation from a PUL defect is of academic interest only, as this anatomical defect is automatically restored by the Intravaginal Sling Operation, part IV, which “reglues” the vagina to the pubococcygeus muscle, (1) (p 58).

**Defect 6 - Striated Muscle Damage.**

A torn external anal sphincter is a rare, but correctible defect. *Paralysis to the muscle floor is not considered to be a primary aetiological factor in female urinary incontinence, but rather, a qualitative contributory factor.*

*Pathogenesis and clinical diagnosis.* Swash in his unifying theory, attributes urinary and faecal incontinence to muscle paralysis (70). However, not all patients with pelvic floor paralysis were found to have urinary or faecal incontinence, and vice versa (70). The frequent finding of muscle paralysis in incontinent patients is explained according to (1), a connective tissue theory, as follows: the foetal head may damage the motor endplate of the pelvic floor, the vaginal connective tissue, or both. The pelvic floor muscles are an important support of urethra (10). Paralysis causes loss of muscle tone (71), so that a prolapsed position of bladder neck and other organs at rest may be caused by a partially paralysed pelvic floor. Many patients whose bladder neck lies below the inferior border of pubic symphysis have been cured by the intravaginal slingplasty procedure without bladder neck elevation (1) (p57). Accordingly we consider that muscle paralysis is not the prime cause of urinary incontinence, but it may induce mechanical inefficiency due to alteration of the angles of force applied at the pubourethral ligament (1) (p13).

*Damaged muscle/insertion of muscle.* Incontinence due to a torn external anal sphincter has been reported, (1) (p75). It is possible for a torn pubococcygeus to cause urinary incontinence (3), but it would be rare with modern obstetrics. A prolapsed levator plate may also be due, at least theoretically, to stretching of the insertions of levator plate to the side walls of the pelvis.

## THE FUNCTIONAL RELATIONSHIP OF URETHRAL AND BLADDER SMOOTH MUSCLE TO PELVIC FLOOR ANATOMY

*The contribution of bladder and urethral smooth muscle contraction to bladder neck opening and closure is adjunctive to that of striated muscle, and is a direct function of the smooth muscle fibres pulling on their insertion points. These insertion points vary in position according to laxity in the vagina and its supporting ligaments, and as to whether or not the various striated muscles of the pelvic floor are relaxed or contracted.*

*Impact of the anatomical insertions of bladder and urethra on opening and closure.* The urethra and bladder smooth muscle function as a unit (9). The smooth muscle contracts against its insertion points: the fibrous tissue connecting the lower 2/3 of urethra to anterior wall of vagina, pubourethral ligament and arcus tendineus fasciae pelvis laterally, pubovesical ligament anteriorly, and vesico-vaginal ligament inferiorly (1) (p19-23). It is obvious on simple examination of FIGS 5, 6, and 7a, that the position of these insertion points is not static. It varies according to the elasticity of the tissues, laxity in the vagina or its supporting ligaments, and how efficiently the forces F1, F2, FIG 3 are applied.

### Opening function.

The superficial trigone extends from bladder base to the external urethral meatus (62). During bladder neck opening, it is stretched backwards by the backward extension of vagina, FIGS 5, 7a. This renders the longitudinal smooth muscle of bladder and urethra semi-rigid, so that it can be actively opened out like a trapdoor, “funneling”, FIG 5, sharply dropping the urethral resistance. Tension of the pubovesical ligament (“anterior shelf”, FIG 4d, prevents the anterior bladder wall from collapsing inwards with the contraction. It also actively holds open the anterior wall of urethra.

**Closure function.** Again, the superficial trigone contracts, and becomes semi-rigid. This elimination of slackness allows the cresta urethralis to be pulled upwards by forward contraction of PCM, FIGS 6, 8,

closing off the urethra. The now firm posterior urethral wall creates a firm cut-off point (“posterior shelf”), FIG 4e, for closure of bladder neck by the downward force F2, FIG 3. Tension of the pubovesical ligament is also important for the “kinking” mechanism of bladder neck closure. It ensures that the anterior urethral wall remains semi-rigid.

We hypothesize that the contribution of bladder and urethral smooth muscle to closure function is adjunctive to the previously described closure mechanisms, rather than primary (7). Laxity in the vagina or its supporting ligaments may not allow the semi-circular smooth muscle sphincters (7) to function efficiently.

### The basis for physiological and unphysiological bladder contraction.

*In this section, many of the conclusions reached by artificially distending the bladder using filling cystometry are questioned on the basis that the bladder may be distended beyond the physiological limit of the patient's continence system, giving rise to the possibility of false results. When the patient presents for testing with a comfortably full bladder, a more physiological provocation may be induced by a hand-washing test. The results from such testing confirm that bladder instability is mainly a premature activation of the micturition reflex, (54) as predicted (1).*

We present the following explanation for the observed phenomena. Stretching of smooth muscle causes membrane depolarization (71). Bladder smooth muscles have characteristics which predispose to tonic contraction and urine loss, including unstable all-or-none action potentials, low-resistance pathways between cells and modification by excitatory or inhibitory nerves (72). From the foregoing it follows that bladder smooth muscle contracts tonically, whether stimulated directly, or by activation of the micturition reflex. It is known that the detrusor pressure registered on cystometry during urine flow (73) is proportional to the urethral resistance. If there is no resistance present, there will be no detrusor pressure recorded, as all the energy from the detrusor contraction is converted to flow.

We hypothesize:

- 1) The filling process causes the detrusor to contract tonically, i.e., it "spasms". This occurs by direct stimulation of smooth muscle, by premature activation of the micturition reflex, or both.
- 2) Measurement of this contraction depends on activation of the urethral closure mechanisms, i.e., if there is no urethral resistance whatsoever, then a detrusor pressure of 0cm H<sub>2</sub>O will be registered.
- 3) Low compliance observed during filling reflects the gradual reflex increase in the slow twitch component of the pubococcygeus/ periurethral striated muscle unit closing off the urethra in response to such a tonic detrusor contraction.
- 4) In patients who register a typical pattern of "detrusor instability", the bell-shaped phasic pattern generally observed, "Y", FIG 15, is not consistent with a physiological spasm of detrusor smooth muscle\*, but may reflect the battle for control between the opening (micturition reflex) and closure mechanisms of the urethra acting against a tonically contracted bladder, oscillating somewhere between the "open" and "closed" positions of urethra, as demonstrated radiologically in FIG 5.
- 5) At the pelvic floor level, these closure/opening mechanisms are activated respectively by pelvic floor contraction, VC and O, FIG 13, W, X, FIG 14. These mechanisms work on a "feedback" system. Such systems involve a time delay, hence the classical bell-shaped curve, "y" FIG 15, seen when there is a reasonably equal balance. The rapid phasic pattern (arrows), FIG 15, is consistent with a phasic striated muscle contraction, in this instance, of the periurethral striated muscle. With large amounts of urine loss, there is an accelerator added to the system, the contraction and depression of the levator plate, FIG 4d. This would have the effect of not only "funneling" the bladder neck and urethra, FIG5, but also greatly increasing the number of nerve impulses from "N", FIG13. The similarity between bladder instability and the micturition reflex is demonstrated directly in FIGS 15a and 15b.

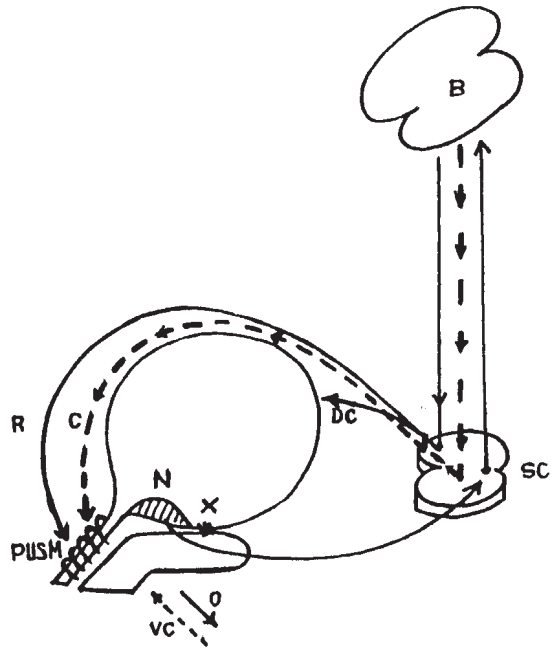
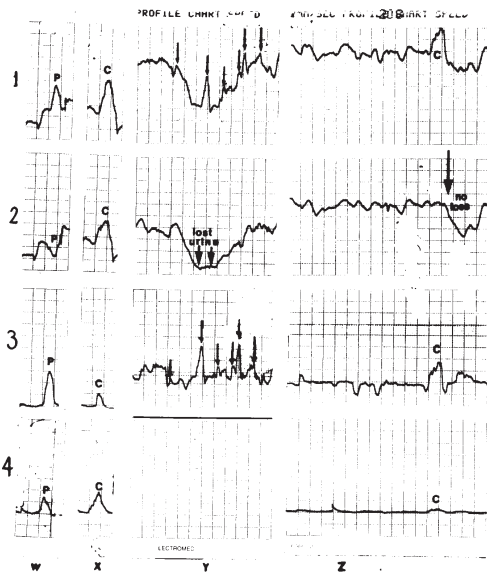

FIG 13

**Schematic outline of "vagal control" of the micturition reflex.**

This is a sagittal schematic representation of bladder, urethra, vagina, spinal cord (SC) and brain (B). "N" = nerve endings at bladder base, PUSM = periurethral striated muscle, X = vesicovaginal ligament. The solid directional arrows represent the micturition reflex - afferent outflow from "N" to spinal cord and brain, and efferent flow to detrusor and urethra: DC = detrusor contraction; "R" = urethral relaxation; O = opening force applied by pelvic floor muscles. The interrupted lines represent a discrete pathway from brain to urethra which inhibits the micturition reflex, and contracts the urethra. "C" = urethral contraction. VC = voluntary closure force applied by pelvic floor muscles.

\* In the normal patient, the stream is continuous, indicating that the detrusor contraction is also continuous.

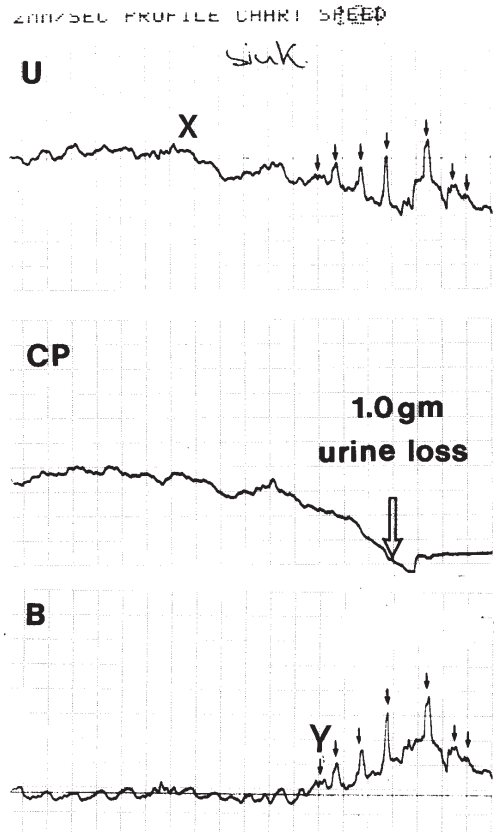

**FIG 14**  
**The effect of pelvic floor contraction on “bladder instability”.**  
 This is a urethrocytometric tracing of a patient with a full bladder.

*Longitudinal Axis:* 1: urethral pressure. 2: closure pressure. 3: bladder pressure. 4: EMG.

*Horizontal Axis:* “W”: straining (P), “X”: “cutting off” (C); “Y”: hand washing provocation - not “holding on” - urine lost; “Z”: hand washing provocation - with “holding on” - urine lost prevented despite partial activation of micturition reflex.(large arrow)

Small arrows = reciprocal pressure rises in bladder and urethra;



**Handwashing**

**FIG 15**  
**Uninhibited premature activation of micturition reflex with urine loss.**

This is a graph of a provocative handwashing (“sink”) test from a patient with symptoms of urge incontinence. “U”= maximal intraurethral pressure; “B” = bladder pressure. “CP” = electronically subtracted closure pressure. X = fall in urethral pressure; Y = rise in detrusor pressure; arrows = reciprocal increases in urethral pressure) and bladder pressure.



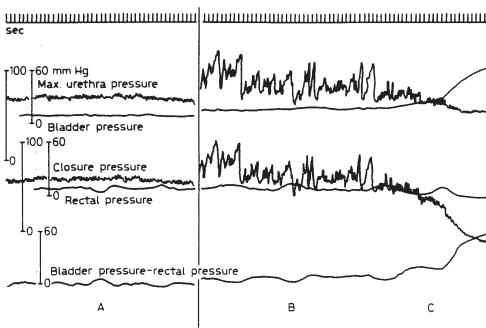

FIG 15a Instability of bladder and urethra induced by filling cystometry

A = quiescent pattern; B = commencement of urethral instability and fall in baseline urethral pressure; C = subsequent commencement of detrusor contraction. Except for the wild swings in urethral pressure, B & C are consistent with the pressure patterns observed during normal micturition in FIG 15b.

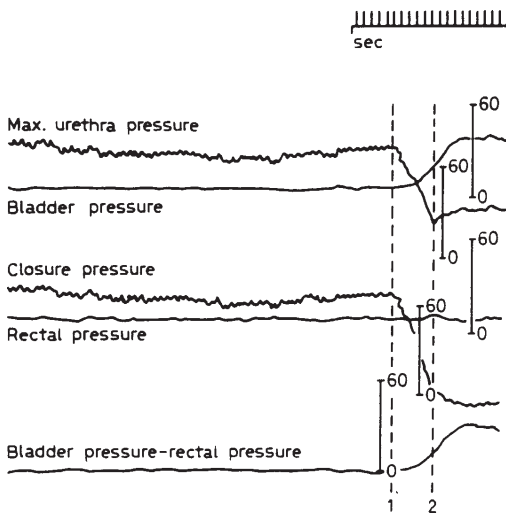

FIG 15b

#### Patterns of normal micturition

Rise in detrusor pressure follows a fall in urethral pressure by some seconds.

## Cystometry

The total expulsive force of the detrusor during a micturition cycle is constant, (73), and does not vary either in stress incontinence, (74), or with an unstable bladder, (75).

Thus if the urethra funnels on provocative testing, i.e. is pulled open suddenly as in FIG 5, there will be a fall in urethral resistance, even to 0 cm H<sub>2</sub>O. Such a pattern was observed in 3/41 patients who lost urine on handwashing provocation (76a). In this instance, the patient will be deemed to not have detrusor instability, even though urine may actually be lost. If the body's mechanisms succeed in closing off the urethra completely, then a high pressure will be recorded in the bladder, with no observed urine loss.

It follows from this, that cystometry alone cannot meaningfully record the events occurring in the unstable bladder in all cases. It can only record the body's attempts at full or partial closure, i.e. the urethral resistance, which appears to be produced mainly by contraction of the pelvic floor (76).

Urethrocystometry, though not perfect, appears to be a superior method, as it has the capacity to also give insight into premature activation of the micturition reflex, being able to record the simultaneous changes in urethral pressure (76a).

## Urine loss during handwashing or showering (FIGS 13,14, 15).

Whether or not urine is lost in patients with "bladder instability" during handwashing depends on the outcome of the struggle between the bladder neck opening (micturition reflex) and closure mechanisms, "O", "VC", FIG13. The inhibitory circuit is suppressed by the act of hand-washing.

Classical patterns of a premature activation of the micturition reflex were recently demonstrated in 115 patients with a history of urge incontinence (76) presenting with a naturally full bladder for urethrocystometric testing comprising hand-washing provocation: first urethral relaxation preceded or accompanied by urge symptoms, then detrusor contraction, following some seconds later, exactly as occurs during normal micturition, FIGS 15, 15a, 15b. We hypothesize that showering or handwashing

suppresses the body's normal control mechanisms over the micturition reflex, by inhibiting voluntary contraction of the pelvic floor "VC", and by counter-acting inhibition within the brain, FIG 13. The action of handwashing cannot be correlated with any of Barrington's reflexes per se. By lifting off the inhibition, however, it allows all 5 reflexes to be activated.

#### **Anatomical correlations for urodynamic events.**

*Whether or not urine is lost in patients with urge incontinence depends on how successfully the vagina below bladder neck can be stretched to support the nerve endings "N", FIG2, by involuntary forward contraction of pubococcygeus muscle ("W", FIG 14) in the normal patient. or by the voluntary elevation of pelvic floor ("X", FIG 14) in the incontinent patient.*

Urethral relaxation during hand-washing provocation depends on the balance between the inhibitory efferents "C", (urethral contraction) or facilitatory efferents "R", (urethral relaxation), FIG 13. Voluntary contraction of the pelvic floor (VC), elevates the pelvic floor, FIG 4e, supports the nerve endings at bladder neck, and may reverse the micturition reflex, as demonstrated urodynamically in FIG 14, Z. Though urethral relaxation, the 1st part of the micturition, large arrow "Z", occurred, the almost simultaneous contraction of pelvic floor "C" apparently aborted the detrusor contraction, so that no urine was lost. If the prematurely activated micturition reflex predominates, and urine is lost, FIG 14 "Y". The opening force "O", FIG 13 will "funnel" the bladder neck, reinforcing the micturition reflex, as in FIG 5. Such "funneling" was noted on VCU in patients with "bladder instability" (65).

#### **Impact of pelvic floor contraction on changes in urethral and bladder pressure.**

*It is mainly contraction of the pelvic floor, not the abdominal cavity, which causes simultaneous increase in urethral and bladder pressures.*

At present, the reciprocal pressure changes in bladder and urethra, FIG 4c, are generally attributed to equalization of transmitted intraabdominal pressure to these organs, (14).

In a study of 163 patients subjected to the urethrocytometric handwashing test (76), the pattern of urethral pressure mirrored exactly that of the bladder in all cases, even during breathing, "b", FIG 16, and even during urine loss, FIGS 14 & 15 (arrows). In 11 out of 163 patients, independent patterns of contraction were noted in the urethra, which were not reflected in the bladder. Using EMG monitoring, urethral pressure rises during straining and on initiation of various pelvic floor reflexes(77), have been previously demonstrated to be accompanied by simultaneous pelvic floor contraction (78). Not all reflexes involved in urethral closure cause simultaneous reciprocal pressure rises in the bladder. e.g. some caused by increased mental activity (79), or stimulation of anterior vaginal wall, "vM" FIG 16, do not. *Contraction of the pelvic floor muscles as demonstrated radiologically, urodynamically, and by EMG in FIGS 4-6 suggests that it may be mainly contraction of the pelvic floor which causes simultaneous increase in urethral and bladder pressures, and not straining per se, as is commonly thought.* We hypothesize that straining derives from the reciprocal relationship which levator ani has with the thoracic diaphragm and the abdominal muscles (80), (81), probably as a result of their common embryological origin (82). Hence, when the body involuntarily closes off the urethra, it does so by activating a pelvic floor contraction, FIG 4b, "S" FIG 4c. This causes a simultaneous reciprocal contraction of the abdominal musculature and thoracic diaphragm, resulting in a secondary rise in intraabdominal (and therefore, bladder) pressure. Similarly, with voluntary closure, FIG 4e, "C" FIG 4c. It is implicit in the equalization theory that the same force which can compress the urethral tube, can also deform and push down the pelvic floor. This is a passive concept, and is generally accepted. However, it is clear on simple observation of FIGS 4b, 4c, and 4e, that the pressure rise during lifting of the pelvic floor and organs on "cutting-off" is similar to that seen during depression of the pelvic floor and organs on straining. Furthermore, EMG recording, FIG 4c confirms the radiological impression of simultaneous pelvic floor contraction.

If the intraabdominal pressure equalization theory were the sole explanation for the pressure rises noted, then there would be no need either for pelvic floor contraction, or for independently innervated urethral contraction, “Vm”, FIG 16.

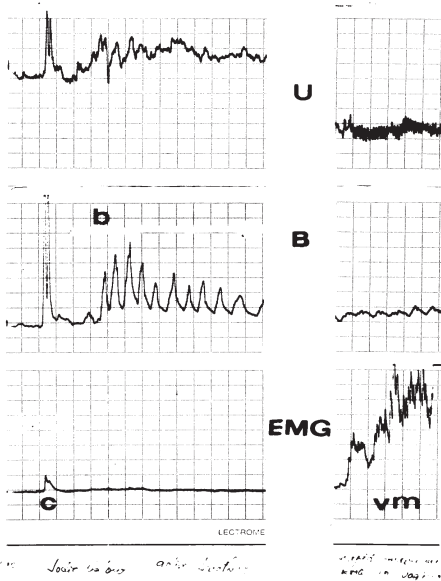

FIG 16

**Examples of coincident and independent urethral contractions.**

U = midurethral pressure; B= bladder pressure; EMG = electromyogram recording in anterior part of vagina. c = coughing “b” rapid breathing; vM = rapid stimulation of anterior vaginal wall.

**False detrusor dyssynergia.**

*The urethra may contract independently of the bladder.*

The signal to relax the urethra may be counteracted by either voluntary, “cutting-off”, “C” or reflex contraction of urethra, “pushing”, “P”, FIG 14, often to the point where there is a relative obstruction to flow giving rise to a false diagnosis of “detrusor dyssynergia” in the absence of neurological disease (78).

**“Better” explanation (59) of some previously discussed phenomena by the Integral Theory.**

Ultimately, according to this theory, all associated phenomena of “detrusor instability”, even in some patients with neurological damage, can be traced to a defect somewhere along the circuits schematically represented in FIG 13.

Some examples\*

Stimulation of a detrusor contraction by effort (19), is explained according to(1) by inability of the forward portion of the pubococcygeus (PCM) to adequately immobilize the vagina below the bladder neck, and so prevent stimulation of the nerve endings by the posterior movement instigated by the levator plate during the bladder neck closure mechanism. The mechanism for this is demonstrated in FIG 12b. Inability of PUL to restrain the vagina may result in sudden massive “funneling”, also resulting in activation of the micturition reflex. In pregnancy, stress and urge incontinence (83), and symptoms of defective opening, (84), are explained by the pregnancy hormones, relaxin, and prostaglandin inducing laxity in the connective tissue of vagina and/or its supporting ligaments. Return to continence after confinement in 95% of patients (83) is consistent with this explanation. Symptoms of deficient opening, as well as high residual urine are explained as follows: laxity in the posterior fornix of vagina inhibits the opening action of the longitudinal muscle of the anus, resulting in a deficient number of afferent impulses from the nerve endings at bladder base, “N”, FIG 13, so that the strength and length of detrusor contraction is likewise suboptimal. *This may explain why the cystometric projections (73) used to calculate work of the detrusor muscle are not applicable in patients with high residual urine.* According to (1), high residual urines are an end point of deficient emptying, and both result from deficient anchoring of the posterior fornix of vagina ( cf posterior fornix syndrome, part IV). The symptom of “stopping and starting” associated with repeated straining is explained as an attempt to further stimulate “N” by pulling the bladder neck down and back, FIG 4b. Urge symptoms due to cystocele/vaginal vault prolapse are explained by causing “dragging” on the vagina at bladder base, or because of concomitant laxity in the supralelevator vagina. Both may stimulate the nerve endings at bladder base. A new incidence of urgency following bladder neck elevation may be explained by the elevated vagina creating upward pressure on the nerve endings at bladder base, thus causing premature activation of the micturition reflex. Thus the very high incidence of “detrusor instability” in the group of operative failures

reported (19) may well have been a self-selected group, i.e. the operation failed because of the excessive elevation causing the new incidence of "detrusor instability". Inflammation causes oedema, and therefore stimulation of the nerve endings in the area. Neural spinal cord disease such as Multiple Sclerosis acts by blocking the efferent inhibitor side of the urethral reflex in the spinal cord. This effectively prevents the action of "C" and "VC", FIG 13. According to the Integral Theory (1) symptoms of frequency, urgency and nocturia at period time may be due to prostaglandins causing laxity of the connective tissue in transverse cervical and uterosacral ligaments, possibly analogous to cervical softening just prior to labour (85). This interferes with the ability of the pelvic floor muscles to create a drum-like support by vagina of the nerve endings at bladder neck. Similarly urinary incontinence and nocturnal enuresis in children is possibly explainable by a congenital defect in the pubo-urethral ligaments or collagenous connection to pubococcygeus muscle (PCM), preventing adequate vaginal tensioning, and therefore support for the nerve endings, and even closure. A similar pathogenesis could explain the stress/ urge incontinence often seen in young women,(86).

\* many examples, such as why the detrusor contraction curve is phasic have already been presented in the text. Others follow in parts II,III, and IV.

Correspondence:  
PE PAPA PETROS  
14A Surgicentre  
38 Ranelagh Cres  
South Perth, WA 6151  
AUSTRALIA  
Fax 61-9-4743766

## PART II. THE BIOMECHANICS OF VAGINAL TISSUE AND SUPPORTING LIGAMENTS WITH SPECIAL RELEVANCE TO THE PATHOGENESIS OF FEMALE URINARY INCONTINENCE

Authors: PE PAPA PETROS, MB BS Dr Med Sc MRCOG FRACOG Dept of Gynaecology Royal Perth Hospital Perth, Western Australia, Dept of Obstetrics and Gynaecology Uppsala University Akademiska sjukhuset Uppsala, Sweden and UUlmsen, MDPHDDept of Obstetrics and Gynaecology Uppsala University Akademiska sjukhuset Uppsala, Sweden

### ABSTRACT

The vagina is presented as a living organ, whose structure, elasticity and tensile properties may be altered by age, pregnancy, parturition, and surgery. An alternative concept for urodynamic pressure measurement is introduced, based on the Integral Theory (1; p63-67), whereby forces creating the pressure in the urethra as measured by a microtransducer, actually derive from the periurethral striated muscle (PUSM). As pressure = force/area, given that the muscle force for a given contraction is always constant, dynamic pressure variations during manoeuvres such as coughing, straining and 'cutting-off' will vary according to the area of the urethral cavity over which the PUSM forces are applied. This area varies according to what degree of urethral closure is attained by the closure muscles acting on the vagina. The relationship of vaginal tension to these forces is analysed with special reference to the stress extension curve of vagina, and also, the various anatomical defects as defined by the proposed Integral Theory.

### INTRODUCTION

In (1), the vagina is presented as a living organ, which cannot regenerate, and whose structure, elasticity and tensile properties may be altered by age, pregnancy, parturition, and surgery. The vagina is assigned a primary role as a transmitter of muscle contraction in urethral and bladder neck closure, and as a structural supporting membrane for the nerve endings at bladder neck. We hypothesize that the "fine-tuning" of the critical tension necessary to allow this dual function involves a complex feedback mechanism between the slow twitch striated muscle fibres of the pelvic floor area, and the brain.

If the vagina is lax, its structural supporting function may be lost. Also, striated muscle contracts over a fixed distance (71). A lax vagina means that the contraction of the muscle inserting into it is dissipated (87). Therefore we consider analysis of the physical, biochemical, and biomechanical properties of vagina to be essential to the understanding of the pathogenesis of female urinary incontinence.

### Effect of age and hormones on the structural components of the vagina.

Age and hormones may cause laxity and therefore, loss of structural integrity of the vagina and its supporting ligaments. More advanced age may cause shrinking of residual vagina after surgery, as well as scar tissue, resulting in the tethered vagina syndrome (1) years after an initially successful operation. The pubourethral ligament and the collagenous connective tissue insertion ("glue") between vagina and the pubococcygeus muscle may also weaken with age, causing severe urinary and even faecal incontinence. What is commonly described as the "vaginal fascia" has been histologically demonstrated to consist mainly of smooth muscle (88). The fascial plane of vagina is actually not a well defined structure (88), has very little strength, and is actually a part of the fascia endopelvina, (88). Structurally, the vagina is weaker than other tissues such as aorta (94)(95). Its strength therefore, must be related to the structural components within its smooth muscle, fascial connective tissue, and the epithelial cells per se.

The mechanical function of connective tissue depends on the structure of the extracellular matrix, and the orientation of the collagen fibres within that matrix (89)(90). The relative proportions of the various glycosaminoglycans influences the mechanical properties of the tissue. e.g., chondroitin 6 sulphate interacts more with collagen molecules than keratan sulphate, which interacts more than chondroitin 4 sulphate etc. During pregnancy, there is a marked change in the ratio of hyaluronic acid to dermatan sulphate, resulting in marked distensibility of the cervix (91)(92). Conversely, the increased content of dermatan sulphate with age, (93) renders the tissue less distensible.

Collagen fibrils appear to reinforce the ground substance much in the same way as glass or carbon fibres provide reinforcement in synthetic composite materials (89). The condition for effective reinforcement is expressed in terms of "critical length" (89) a function of fibril radius, the stress at which fibrils break, and the shear stress exerted by the fibril. A decreased critical length (scurvy) or increased critical length due to increased cross linking of collagen (ageing) may actually impair reinforcement (89). During pregnancy, part of the mechanism for softening in experimental animals may be due to the effect of relaxin inhibition of lysyl oxidase, the main collagen covalent cross-bonding enzyme (92). Once the tensile limit of a tissue is reached, individual fibrils may break, so that the others become overloaded. In this way, the tissue may fail catastrophically (89). Though the collagen fibrils themselves increase in strength with age, a net loss of tissue strength with age has been demonstrated by direct testing (94). The standard deviation of the physiological age of tissues is approximately 25% between the ages of 40 and 80, i.e. a patient with a calendar age of 60 years may have tissues with a physiological age ranging in extreme circumstances between 30-90 years, but more generally between 45 and 75 years. *On this basis alone, the propensity for surgical failure due to poor strength/elasticity of vaginal tissues, present and future, is huge.* Data of tissue breaking strain, (94) indicates that the vagina does not have strong structural components when compared to other tissues of the body, e.g. skin, artery, tendon etc (94) (95).

Mechanical influences aside, we attribute the appearance during pregnancy of stress and urge symptoms (83), and symptoms of defective emptying (84), to hormone induced laxity (1) (p77-78) of the vagina. This laxity is mostly reversible (83). Symptoms of stress and urgency, during pregnancy can often be alleviated by insertion of a ring pessary. This stretches the vagina, removes laxity, and re-creates the tympanic membrane essential for opening, closure, and support of nerve endings at bladder base. Perimenstrual urge/stress symptoms may be ultimately caused by prostaglandins and other hormones loosening the cardinal and uterosacral ligaments along with the cervix, (defect no 4, classification, FIG 2), possibly analogously to what occurs during cervical ripening (91). The above manifestations are consistent with the concept of vaginal laxity causing various symptoms of urinary incontinence (1).

#### **Structure and function of ligaments.**

The mechanical properties of the various tissues are related to the differences in alignment of the collagen fibres. Skin is weaker than tendon because fewer fibres are oriented in the direction of loading (90). Structural orientation varies in different ligaments depending on function. Although most ligament collagen fibres are nearly parallel, some have a non-parallel orientation. The strength of collagen is a function of its inter and intra molecular cross-bonding (96), with identifiable increases in particular types of cross-linking. Load bearing ability of collagen increases with age (96). The biochemical processes of aged collagen are complex, and include an oxidative mechanism (97). Loss of elasticity in human tissue occurs after the age of 40 (96), as can be seen by comparing FIG 7a with FIG 7b.

When the ligaments are unloaded, collagen fibres have a wavy configuration. When loads are imposed, low loads are sustained until the fibres oriented in the direction of loading, straighten out. At this point the straightened fibres sustain loads in the physiological range. This also provides a "shock absorption" function for vagina and urethra FIG 7a. Elastin allows a tissue deformed by stretching to return to its original state on release of the deforming force, FIG 7a. *Thus the elasticity of vagina and urethra is a low energy method*

of retaining urethral closure in the normal patient. We believe the acute rise in detrusor pressure at the end of micturition as being due to this restoring force.

### Structural failure.

The elastic component of vagina is susceptible to rupture with relatively light loads. Therefore any stretching of vagina during surgery must be carried out with care. Deformation to failure depends on the qualities of collagen and elastin. Elastin fibres display great elongation (more than two times the original length when low loads are imposed). With increased loads, they suddenly become stiff and rupture abruptly without deformation (92). On extension, collagen fibre become stiff and reach their yield point, generally without breaking. Therefore, over- extension of vaginal tissue may principally destroy the elastin content of the tissues. Once the elastin has been broken, say by excessive elevation of vagina or by childbirth and subsequent herniation, then the collagen fibres align along the lines of force, (gravity). In the urethra, this may cause laxity, a low urethral pressure (1), and 'constant seepage of urine'.

### Biomechanical properties of vagina.

*Advancing age weakens the structural integrity of vagina, and changes its stress elongation curve. This narrows the margin for error with incontinence surgery.*

The vagina has a dual role. It structurally supports the nerve endings at BN, and transmits the contractile forces from PCM and LP, FIG 17 generated by the pelvic muscles. The stress elongation curve of vagina is almost identical to that of the trigone in the urinary bladder (94), indicating that the trigone will be stretched synchronously with the vagina on application of a force.

Point (X), FIG 17, represents the point where the vagina can stretch no more and becomes a rigid transmitting membrane. Any force applied beyond point (X) is then faithfully transmitted to whatever the vagina is connected to, i.e. the lower 2/3 of urethra, and to bladder base. The initial elongation limit of urogenital tissues ( to point X, FIG17), is 20%-35% of the ultimate strength; initial elongation = 60%-80% of the ultimate elongation (97). The ultimate tensile strength of the urogenital tissues is

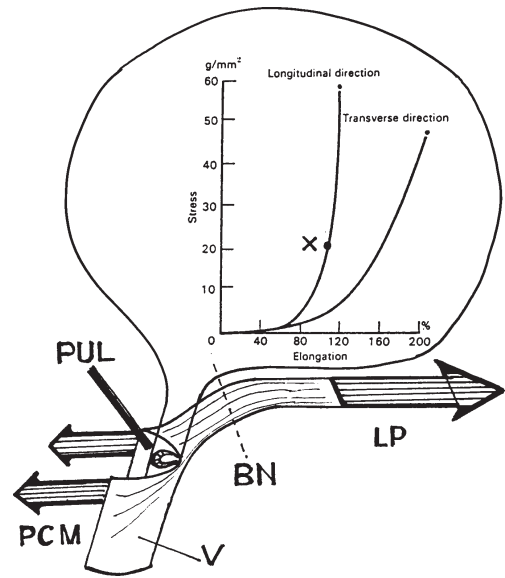

FIG 17

### Differential extension of vagina.

This represents a standing lateral sagittal section of the bladder and its anatomical supports. PUL = pubo-urethral ligament; BN = bladder neck; LP = levator plate; V = vagina; PCM = pubococcygeus muscle; Inside the bladder is a stress extension curve of vagina. "X" = stretch limit.

greatest between 10 and 29 years, but by 50 to 79 years the strength has decreased to about 60% (98).

### Function of differential vaginal tension.

*Less extensibility in the longitudinal axis of vagina ensures that a semi-rigid " spine" , FIG 17a, in the posterior urethral wall is quickly created, ensuring that opening and closure of the urethra may proceed efficiently.*

Like other urogenital tissues (97), the vagina has a differential elongation longitudinally and transversely. Tension in the longitudinal direction, is achieved by contraction of the levator plate (LP). This is radiologically demonstrated in FIGS 5, 6, 7a, 7b. Tension in the transverse direction, is achieved by forward contraction of the pubococcygeus muscle (PCM), pulling the vagina forward. This is radiologically demonstrated in FIG 6, where the midurethra is obviously pulled forward during straining, "S".

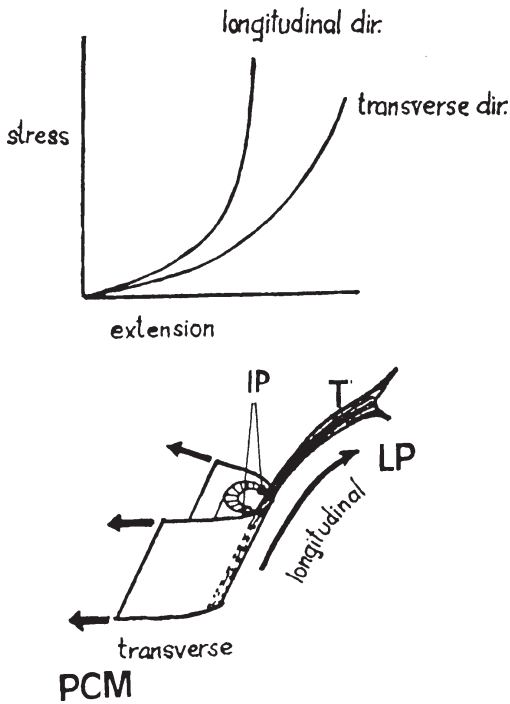

**FIG 17a**  
**How differential extension of vagina aids opening and closure of urethra.**

Standing sagittal section. LP = levator plate; PCM = pubococcygeus muscle; T = superficial trigone; IP = insertion points of periurethral striated muscle.

Because point “X”, is reached earlier in the longitudinal direction, it converts the posterior wall of urethra into a semi-rigid structure, so that it can now be pulled forward by PCM to close urethra, or pulled down for opening/closure by subsequent contraction of LMA, i.e. the urethral tube is opened and closed antero-posteriorly along most of its length, as demonstrated in FIG 5. *This is a much more efficient arrangement for a sphincter mechanism than circular closure at a singular point.*

As the urethra lengthens during closure, FIG 3, so does it become narrowed. This applies especially to the upper 1/3 of urethra which has no vaginal attachments. According to the law of Laplace, the tension acting in the lumen increases, aiding closure.

**Biomechanical effect of changed elasticity.**

*Decreased elasticity means that the point on the stress extension curve where the force is transmitted, instead of being absorbed by stretching the elastic components, is reached much earlier. Vaginal scarring may vastly accelerate this process.*

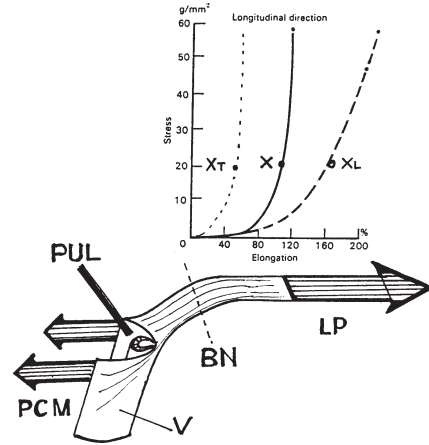

**FIG 18**  
**Influence of vaginal elasticity on muscle force transmission.**

This is a stress extension curve of vagina. XT = poor vaginal elasticity, e.g. from scarring at bladder neck; X = normal elasticity; XL = vaginal laxity; PUL = pubourethral ligament; BN = bladder neck; LP = levator plate; V = vagina; PCM = pubococcygeus muscle.

In FIG 18, low vaginal elasticity, as in curve XT, means that the point of transmission is reached much earlier along the elongation axis. This pattern is typically seen in the “tethered vagina syndrome”. If the vagina is lax, as in curve XL, a significant amount of the muscle contraction is wasted in extending out the laxity. Point X may never be reached, so that urethral closure may not occur.



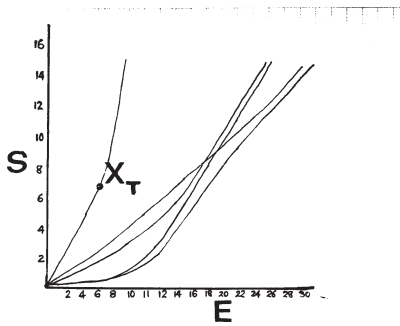

FIG 19a

Stress elongation curve in the transverse diameter of vagina in the area of bladder neck in five postmenopausal patients with stress incontinence, as measured “in vivo”, by a prototype elastometer. S = force applied; E = extension of vaginal wall.

This is an actual stress-elongation graph taken in the transverse axis of vagina in the region of bladder neck, in four SI females (to the right in the diagram) and in a patient with the “tethered vagina syndrome” (XT), using the prototype elastometer instrument depicted in FIG 19b. Very little stretching of the vagina would be needed to reach (XT) in the patient with tethered vagina. A bladder neck elevation operation would most likely worsen this patient’s symptoms, by removing any remaining elasticity from zce, FIG 3. By the same token one could proceed to such an operation in the other 4 females with confidence.



FIG 19b

Prototype elastometer. D = distance between hooks; E = extension distance; F = variable force.

Lose (99) demonstrated 2 distinct patterns, similar to FIG 19a on measuring urethral elasticity. We explain his results as being secondary, and dependent on, how much the vagina was stretched by the catheter within the urethra, given our concept that the smooth muscle extension of the bladder/urethra unit is ultimately limited by their insertion points into the vagina.

### How vaginal laxity limits the effect of pelvic floor exercises.

It is clear from examining “C” FIG 6, how learning the voluntary closure mechanism with pelvic floor exercises can stretch the vagina upwards, facilitating point X, FIG 17, being reached during closure with a lax vagina. As striated muscle contracts over a finite distance (87), however, there is a limit as to how much extra efficiency can be squeezed out of the system. Even with patients who are greatly improved, further age-related loss of elasticity inexorably results in a return of symptoms. Given the evidence presented here as concerns the urethral and bladder neck closure mechanisms, and the important role of the pelvic floor muscles therein, it would appear that pelvic floor exercises incorporating straining/pushing in the normal patient would also be essential in prophylaxis, something not presently recognized by physiotherapists.

### Visco-elastic “creep”.

*Over a period, the muscle forces acting on the vagina have the potential to loosen any surgically imposed tension.*

In this context, visco-elastic “creep” is defined as the gradual flow of a material under a sustained load. Each tissue will have its limit, e.g. the “creep” limit for the urinary bladder of dogs and rabbits is 60% of the ultimate strength of the tissue (95), whereas the initial elongation limit is only 20-35% of the ultimate tissue strength (94). This may explain why it has evolved that in vaginal surgery, much larger tracts of vagina are routinely excised than would appear necessary ( cf surgical recommendations, part III). This technique, without realizing it, anticipates the process of visco-elastic “creep”.

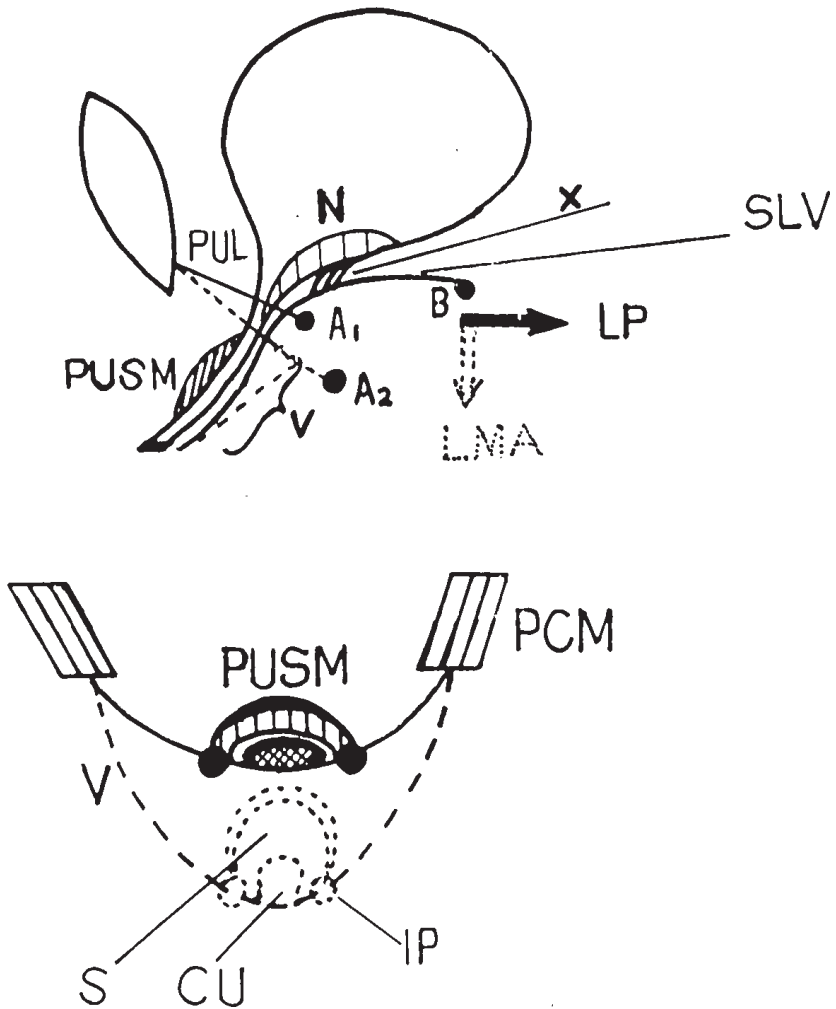

FIG 20

**The mechanics of lowered pressure transmission ratio.**

vaginal laxity (broken lines), may result in failure to achieve the "closed" position (solid lines) during coughing or straining. The urethra remains relatively "open" (broken lines). Thus the dynamic increase in pressure from PUSM is exerted over a larger area "S". As the contractile force is always constant (100), a low transmission ratio signifies that "CU" is not tightly apposed to PUSM at the point of measurement.

Upper diagram represents a sagittal section of the anterior wall of vagina, urethra, and bladder. V = vagina underlying the lower 2/3 of urethra; PUL = pubourethral ligament; PUSM = periurethral striated muscle; N = nerve endings at bladder base; X = vesico-vaginal ligament; SLV = supralelevator vagina; A1 = vaginal attachment of PUL; A2 = the same attachment stretched by contraction of LP (levator plate) and LMA (longitudinal muscle of the anus); B = insertion of uterosacral and cardinal ligaments. Lower diagram represents a transverse section of the mid urethra; PUSM = periurethral striated muscle; V = vagina; IP = insertion points of PUSM; CU = cresta urethralis; S = space between PUSM and CU (the area over which PUSM contracts); PCM = anterior portion of the pubococcygeus muscle. The broken lines 'open' position; solid lines: closed position.

“Creep” is explainable in terms of the initial distension being due to the stretching of collagen and elastic fibres, subsequent rearrangement being due to the molecular adjustment of the ground substance to this increased load. We attribute the gradual return of ability to micturate following urinary retention subsequent to a tight vaginal repair, or bladder neck elevation procedure to the visco-elastic “creep” equalizing the tissue tension in vagina between USL and external urethral meatus, relieving tightness, and permitting F2, FIG 3, to once more actively open the bladder neck. *We believe that overdistension of smooth muscle is unlikely to be a major mechanism in the causation of post-operative urinary retention, as smooth muscle, unlike striated muscle, can function effectively over a large range of distension lengths (71).* Similarly, transient urge symptoms seen after vaginal repair are explainable by a temporarily excessive tension from below stimulating the bladder base nerve endings (1) (p55), with “creep” explaining the subsequent release of tension, and therefore, relief of symptoms.

#### **Loss of urine with repetitive coughs.**

*Tissue hysteresis inhibits the restorative elastic closure force of urethra, facilitating urine loss with repetitive coughs.*

We attribute loss of urine subsequent to initial non-productive coughing to a hysteresis factor preventing adequate recoil of the elastic structures PUL, SLV, V, FIG20. The space “S”, FIG 20, increases with every cough.

#### **The dynamic interpretation of muscle force as reflected by pressure transmission ratios.**

*It is our concept that pressure readings have an important role in the dynamic assessment of the various closure mechanisms, as they have the potential to measure force. Pressure = force/area.* According to (1), the urethral “cavity” is subjected to three different forces originating from three different muscles during opening/closure, FIG 3. In sequence (LP) moves backwards, then (PCM) forwards and finally (LMA) downwards. These events instantaneously alter the intraurethral area on which the periurethral striated muscle acts.

Pressure = force/area. Vaginal laxity increases the intraurethral area (“S” FIG20) over which the striated muscle force (“PUSM” FIG20) acts; i.e. pressure transmission ratio will be diminished during certain manoeuvres if the muscle forces cannot close the urethra, because the force of muscle contraction is always constant (100). In the normal patient, there is a degree of over-compensation by the muscle forces activating the involuntary closure mechanisms, hence pressure transmission ratios well in excess of 100% are frequently recorded on coughing.

Vaginal laxity, (broken lines FIG 20), increases the space “S”. Therefore (PUSM) contraction is exerted over a relatively larger area and this is reflected in a negative pressure transmission ratio, as noted for straining, coughing, and “cutting-off”, FIG 21a.

#### **Interpretation of PTR changes according to various manoeuvres.**

*The pressure transmission ratio (PTR) is a potentially powerful tool for estimating the relative diminution of muscle force transmission caused by vaginal laxity. When combined with knowledge of the directional force of pelvic muscle contraction, F1 F2, FIG3, and observed laxity in positions 1-5 of vagina, FIG2, PTR may assist in the diagnosis of specific anatomical defects as per the classification.*

NOTE: In the following graphs, “pushing” (P) is synonymous with “straining” (S).

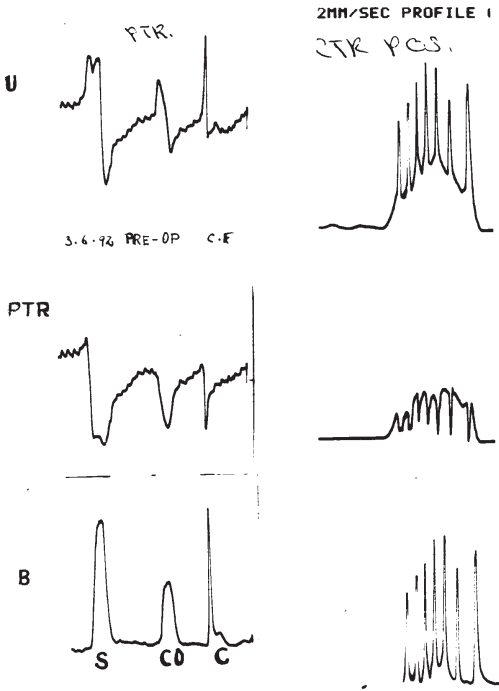
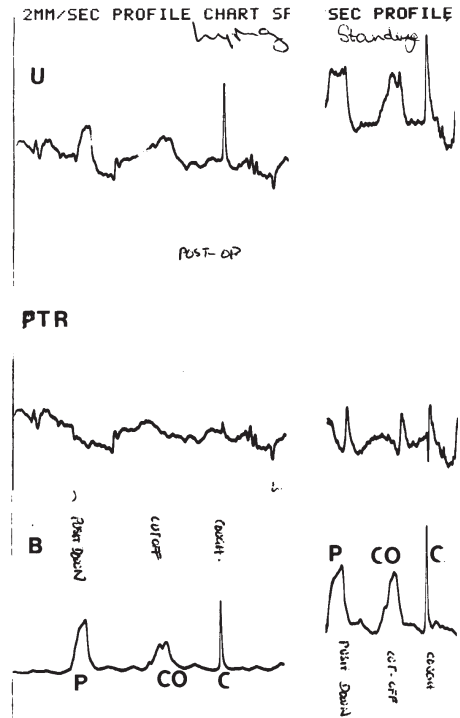

**FIG 21a**  
Pre-operative pressure transmission ratio in the supine position.

on pushing (S), "cutting-off" (CO) and coughing (C); U = mid-urethral pressure; B = bladder pressure; PTR = pressure transmission ratio. POS CTR indicates that the transducers were oriented posteriorly.

The dynamic interpretation of urethral pressure readings is further demonstrated in FIGS 21a and 21b in a patient who underwent the IVS (intravaginal slingplasty procedure). This operation tensions the suburethral vagina, and creates an artificial pubourethral ligament (PUL).

In the preoperative graph, PTR, FIG 21a, is negative during 'pushing', "cutting-off", and coughing, i.e. the vagina is so loose, that PCM cannot close the urethral space "S", FIG 20.



**FIG 21b**  
Postoperative pressure transmission ratio in the supine and standing positions.

U = mid-urethral pressure; B = bladder pressure; PTR = pressure transmission ratio P = "pushing" (Valsalva); CO = "cut-off"; C = coughing.

In the postoperative graph, FIG 21b, in the supine (lying) position, PTR during coughing (C), has reverted to normal, but not PTR on "pushing" (P), which is slightly negative. In the standing position, however, PTR on "pushing" (P) has now become positive. Hypothesized interpretation: In the standing position, the levator plate (LP), FIG 17a, is contracted, and so the vagina is already partly stretched longitudinally. In the supine position, LP is relaxed. Some of PCM's energy is expended in stretching that part of vagina normally stretched by LP in the longitudinal axis, FIG 17a. The work performed by a muscle for a given nerve stimulus is constant (100). Therefore less energy is available to close off the urethra which remains relatively open. Hence a low PTR is recorded.

### **Paradoxical leakage**

*is defined as leakage on bending, which occurs at a lower pressure than coughing, (which does not provoke leaking). Paradoxical leakage is explainable by a prolonged active stretching downwards of the anterior vaginal wall by the LMA due to low elasticity in the ZCE, or deficiency in PUL, FIG12b. This actively pulls open the urethra/bladder neck. As such it is not strictly stress incontinence, an essentially passive concept, even though the urine loss is provoked by effort.*

Hitherto, leakage on bending over, or getting up off a chair has been generally considered as stress incontinence. We have found that many patients with pubourethral defect, or with the tethered vagina syndrome did not have SI on coughing, yet leaked at a far lower pressure on bending or standing, (1) (p63-67). With the tethered vagina syndrome, the cough stimulus, FIGS 21a, 21b, 22, lasts no more than half to one second. This is just sufficient to stretch vagina rapidly to just short of point (XT), FIG 18. This leaves just sufficient elasticity in the zce, FIG 3, so that F1 and F2 may proceed independently to close off urethra and bladder neck. Straining lasts three to four seconds, point X is reached and maintained, so that in patients with scarring at ZCE or deficient PUL, FIG3, F2 may now oppose F1. The bladder neck is pulled open on being given the signal to close at a lower pressure than during coughing, “paradoxical leakage”.

### **The effect of contraction time on the pressure transmission ratio.**

We hypothesize that the muscles LP, PCM and LMA exert their action in this sequence. The contraction time of this sequence, and its interaction with the various anatomical defects 1-6, FIG 2, determines the symptomatic presentation, and the pressure transmission ratio ( PTR ) which is registered.

During coughing, FIG 21b, left-hand graph, PTR is positive for coughing (C), but negative for straining (P). During coughing, the force from LP FIGS, 17a, 18, is exerted only over half to one second. Point X is reached first in the longitudinal axis, then later in the transverse axis. LMA is minimally activated, so that space “S”, FIG20, remains small. The residual

elasticity in the transverse diameter of vagina therefore allows the PCM (F1) to move the cresta urethralis forward a fraction later to close off the urethra, independently of LP. During straining, however, LP/LMA (F2) is exerted over three to four seconds so that if F1 cannot effectively close the urethral cavity, the posterior urethral wall is pulled open like a trap-door, enlarging the urethral “cavity”, and causing PTR for straining, P (FIG 21b), to become negative. During “cutting-off, “CO”, the pelvic floor, rectum, vagina and bladder neck are lifted upwards and forwards, assisting point X, FIG17 to be reached in both axes, so facilitating urethral closure. This “stretching up” action on the vagina is morphologically demonstrated in FIGS 4e and 6. During “cutting-off, “CO” (FIG 21b), F2 is not activated at all. F1 closes the urethral space, so that PTR for “CO” is positive, even though the contraction lasts 3-4 seconds.

### **Significance of a low cough transmission ratio in SI.**

*A lax vagina delays urethral closure, increases the area over which the striated muscle force is exerted, therefore decreasing the cough transmission ratio.* We have demonstrated how the “pinch test” (1) (p33-35) may increase the cough transmission ratio (CTR). Similarly, injection of distending fluid periurethrally may tension the insertion points (IP) of periurethral striated muscles sufficiently to allow isometric contraction of those muscles, also increasing the CTR, FIG 10. It follows that a low CTR, FIG 21a, probably indicates a lax suburethral vagina in the presence of an intact PUL. If so, such a patient has a high possibility of cure by vaginal repair. We believe that peri-urethral GAX collagen injections work similarly to the process in FIG10, i.e., taking the laxity out of the transverse diameter of vagina decreasing “S”, FIG20, and also, anchoring the insertion points (IP) of PUSM, FIG20.

### **Significance of a high cough transmission ratio in effort/stress incontinence.**

The sequence of pelvic floor muscle movements, LP, followed by PCM, then LMA, means that over the 1/2 to 1 second over which these movements occur, the contribution of LMA is minimal, i.e. any situation which facilitates extension of the posterior wall of

urethra in the longitudinal axis may create a high cough transmission ratio. This may occur even in the presence of a lax suburethral vagina, especially if there is a deficient PUL fulcrum preventing the separate actions of PCM and LP.

We have regularly noted that CTRs of 100% are frequently found in incontinent patients with obviously lax suburethral vaginas. We explain this by loss of the PUL fulcrum function, FIG 12b. If PUL is loose, then differential LP contraction during the cough pulls the vagina back sufficiently to tension it longitudinally. This movement anchors the (PUSM) insertion points, FIG 8, ensuring efficient contraction and a high CTR\* (1) (p37-39). Patients with non-stress non-urge incontinence(1) (69-70), or with the tethered vagina syndrome (1) (63-67) often did not lose urine on coughing. They did lose urine on getting out of bed, or off a chair. We explain this as being due to subsequent prolonged pelvic floor contraction opening the vagina (and therefore urethra) like a trapdoor, FIG 20, broken lines, "S". The marked elongation of vagina possible with a PUL defect is obvious in FIG 12b.

\* Despite the high CTR, urinary leakage may still occur, as water-tight closure requires elevation of the cresta urethralis and tightening of the vagina by the PCM, FIG 8.

### Adjunctive concept for aetiology of stress incontinence.

We suggest that stress incontinence may not be entirely a passive process. Given the sequence of muscle movements, LP, PCM, LMA, FIG 2, then if PCM cannot be activated, the system is thrown from the "active closed" to "open" position, i.e. it is likely that the urethra may be actively opened, at least in part during stress, by the events occurring in FIG 12b.

### Positive Valsalva PTR in the incontinent patient.

*This may suggest a posterior fornix defect.*

We have recently performed a Valsalva PTR test in 10 asymptomatic nulliparous controls, and 163 female patients with urinary incontinence (unpublished data). All females were tested with a full bladder. According to our results, the PTR straining test was mostly positive in control patients, and mostly negative in incontinent patients with a full bladder. This is

consistent with previous reports (102). However, we found that PTR on straining was positive in 21 incontinent patients. The incidence of hysterectomy in this group was 14/21, i.e. 66%. Using a two sample test of proportions,  $p = .0008 (< 0.001)$ ; i.e. hysterectomy seems likely to be a causative factor. One explanation for this may be according to (1) p 71-73, that transverse suturing of the vaginal vault during hysterectomy may cause laxity in the posterior fornix, so that the LMA contraction can no longer properly tension the supraleator vagina, FIG 2. This may lead to defective bladder neck opening and/or closure.

FIG 22 indicates how an incontinent patient cured by a posterior fornix repair (part IV), this issue), converted a positive PTR to normal.

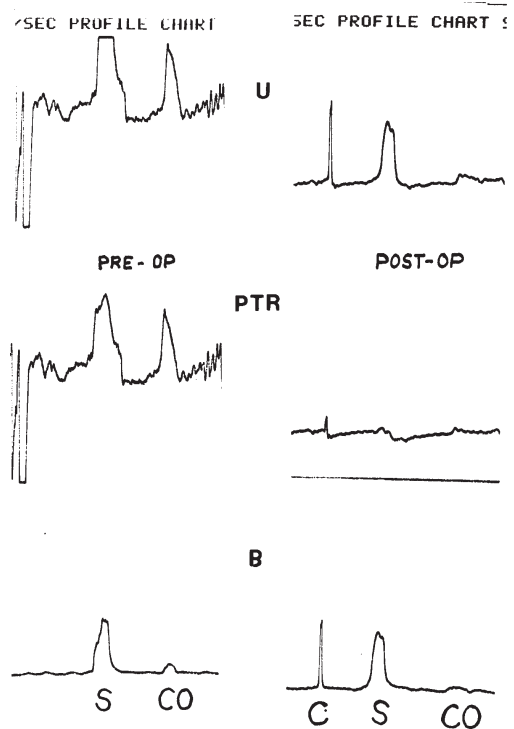

FIG 22

### Change in PTR following posterior fornix repair.

This is a pre- and postoperative graph of a patient with stress and urge incontinence due to a posterior fornix defect who was cured by a posterior fornix repair S = strain; CO = "cut-off"; C = cough; B = bladder; U = urethra; PTR = pressure transmission ratio.

### Interpretation of the valsalva PTR test according to (1).

In FIG 22, pre-operatively, PTR on straining (S), in the lying position, is positive, a pattern found frequently, but not always, in patients with urinary incontinence due to a posterior fornix defect, (defect no 4, FIG 2). This patient was surgically cured by making a 4 cm horizontal incision in the posterior fornix of vagina, stretching it up longitudinally, and suturing it side to side. Postoperatively, the PTR has converted to being only slightly negative. Interpretation : preoperatively, LMA contraction was weak because of laxity in the uterosacral ligaments. "V", FIG 20, could not be pulled open by LMA, "S" remained narrowed, and PTR was recorded as positive. The operation tightened the uterosacral ligaments, LMA contraction returned to normal, "V", FIG 20, was pulled down on straining, "S" increased, and PTR was recorded as normal - slightly negative. PTR "C" (coughing) FIG 22, is positive, because vaginal stretching is much less over 1/2-1 second, so that the urethra is not opened significantly. PTR during "cut-off" is positive throughout, due to a different mechanism which elevates the vagina, best demonstrated in FIG 6.

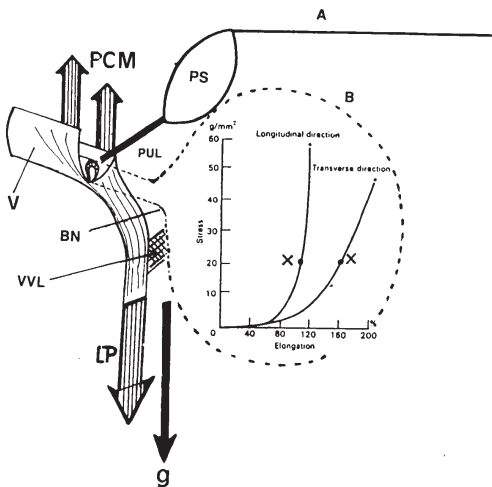

FIG 23

### The urethral closure system has limited muscle strength.

This represents a sagittal section of a patient lying in the supine position. A = rectus sheath; B = urine-filled bladder; g = force of gravity (inertial load) acting on the full bladder; VVL = vesicovaginal ligament; labelling otherwise as in FIG 17 stress - elongation curve of the urogenital tissues is contained inside the bladder.

### Relationship of cough transmission ratio to bladder volume, vaginal laxity, and urge incontinence.

*Increasing bladder volume increases the inertial load 'g' on the urethral closure muscles for the 1/2 - 1 second duration of a cough, FIG 23. This delays urethral closure, increases the area over which the striated muscle force is exerted, thereby decreasing the cough transmission ratio. A lax vagina exacerbates this situation. If all structures are intact, then force "g" is exerted mainly at "BN", bladder neck. If the vagina is lax, there will be funnelling, so that "g" also stretches part of the suburethral vagina providing a larger counter force to PCM, than in the normal patient. This delays urethral closure even further, increases the area "S", FIG 20 over which the PUSM striated muscle force is exerted, therefore decreasing the cough transmission ratio. This concept may be further developed to explain nocturia and nocturnal enuresis. Overnight, as "B" increases in volume, the nerve endings at "BN" become stretched by the funnelling, activating the micturition reflex. With nocturnal enuresis, we postulate that congenital defects 3 and/or 5 do not allow PCM to create a drum-like tension in the vagina, to support the bladder neck nerve endings, thereby preventing such activation of the micturition reflex.*

In an ongoing study (unpublished data), the relationship between CTR bladder volume and urine loss on handwashing provocation is penetrated. Fifty-two patients (group 1) with a previous history of mainly urge incontinence, lost urine during the handwashing test. They were compared with a similar group of 63 women (group 2) who did not lose urine during this test. The mean cough transmission ratio CTR in group 1 was 76%, and 92% in group 2. Mean bladder volumes were 453 mls and 353 mls respectively. Using a 2 sample t test, the correlation between the lowered CTR and increased bladder volume in the two groups was found to be highly significant,  $p = <.00001$ . i.e., it is highly likely that the increased bladder volume was responsible for the low CTR in the patients who lost urine during the handwashing "sink test".

These results are consistent with those reported by Constantinou, that CTR decreases with increased bladder volumes in healthy females (101).

With reference to (1), we hypothesize that the PCM muscle force, FIG 23, was unable to tighten the vagina sufficiently to prevent stimulation of the nerve endings at bladder base, or to close off the urethra sufficiently during coughing (low CTR), due to the increased inertial force created by the additional weight of urine. We consider that the results confirm the main statement of the Integral Theory (1), that stress incontinence (defective urethral closure) and urge incontinence (inability to inhibit premature activation of the micturition reflex) both derive, for different reasons, from the same anatomical defect, vaginal laxity in the suburethral/bladder neck region.

#### **Force generated by the pubococcygeus muscle.**

The anterior portion of pubococcygeus muscle(PCM)FIG23 generates a constant force for a given stimulus, (100) . Force =  $M \times a$  , where M= mass and a = acceleration. If M increases (higher urine volume), 'a' decreases, as does the terminal velocity of the contracting muscle. In group 1, "S", FIG20, is enlarged due to the inertial force of the extra urine. Thus some of the muscle force generated is required to overcome this inertia. "S" FIG 20 does not close, as X, FIG 17, may not be reached. This reduces the CTR. Using the relationship between the reduced CTR and increased urine volume reported earlier, we calculated # that the total strength of pubococcygeus muscle contraction = 6.88 Newtons, and the power = 99.2 mW.

# see appendix B.

#### **Power generated by the pubococcygeus and periurethral striated muscles.**

At the level of midurethra, mean power for healthy women was 4.0 mW, and for GSI women 2.0 mW, (99). We believe that we have measured the power exerted by the pubococcygeus, and that Lose (99) has measured the power of the periurethral striated muscle. These results reinforce our concept of the urethral closure mechanism having 2 components, a powerful pubococcygeus muscle contraction component (generating 99 mW), and a much weaker periurethral striated muscle contraction (generating 4 mW).

#### **CONCLUDING COMMENTS**

Though several examples of how various dynamic pressure transmission ratios may reflect specific morphological defects have been presented, it must be remembered that the mechanisms of closure are complexly interlinked, and most probably, chaotically determined, much in the same way as with "detrusor instability". Therefore a specific pattern may not necessarily be registered on one occasion, or repeatable on another.

#### **Correspondence:**

P.E. PAPA PETROS  
14A/38 Ranelagh Crescent  
South Perth WA 6151  
Australia  
Fax: 61-9-4743766



## PART III: SURGICAL PRINCIPLES DERIVING FROM THE THEORY

### FOREWORD

The following section is not meant, in any way, to be a definitive handbook of urogynaecological surgery. Rather, the aim is to present our interpretation of the surgical principles derived from the Integral Theory. In the process of applying the theory to the management of female incontinence, the surgical principles described herein, and even the theory itself have been challenged, refined and modified. Most of the statements introduced are based on a significant clinical experience based over several years, encompassing close to 1000 patients. In the patient not previously operated upon, defects no 3 & 5, pubourethral ligament (PUL) and collagenous insertion (“connective tissue glue”) of vagina to the under-surface of pubococcygeus muscle are considered to be the most serious defects, as they also invalidate the urethral closure mechanism, and appear to have a role in the causation of faecal incontinence too. However, we also emphasize the role of a lax posterior fornix as concerns causation of high residual urine, pelvic pain, and also, urinary incontinence.

### ABSTRACT

The impact of surgery on the six structural defects according to the initial anatomical classification (p14), is analysed with reference to the 3 main functions of vagina and its supporting ligaments: as an elastic membrane connecting the urethral and bladder neck closure mechanisms, FIG3; as a transmitter of pelvic muscle contraction, FIG17; as a structural support for the nerve endings at bladder base, FIG 13. Future problems to be solved include how to more accurately diagnose a particular anatomical defect, precise pre-operative assessment of vaginal strength and elasticity, and how surgical methodology must take into account the long-term effects of ageing and scarring on connective tissue.

---

### INTRODUCTION

Like any other organ the vagina cannot be re-created once it has been surgically destroyed. As living tissue, it is subject to age changes such as loss of elasticity, loss of structural strength, and to hormonal changes in pregnancy. As a birth canal, it may be structurally damaged, resulting in herniations and laxity. All these factors impact on the three functions of vagina and its supporting ligaments:

- 1) as an elastic membrane, zce, FIG 3 connecting the urethral and bladder neck closure mechanisms, allowing them to function independently.
- 2) as a transmitter of pelvic muscle contraction for opening and closure, FIGS 2 & 3;
- 3) as a structural supporting membrane for the nerve endings at bladder base, preventing their premature activation, FIG 13.

These three properties have the potential to oppose each other. The problem is solved in the living patient by active “fine-tuning” of the structural

components of vagina by slow twitch striated muscle, and nervous control of smooth muscle.

### REASONS FOR SURGICAL FAILURE

#### The tissues.

We consider the increasing failure rate of incontinence surgery with time (103) as being principally a direct function of age-related changes in the vagina, due to increasing suburethral or posterior fornix laxity, or tightening of the supralelevator vagina due to scarring, or even loss of collagen “glue” between pubococcygeus muscle and vagina. Difference in elasticity is dramatically illustrated by comparing FIGS 7a and 7b, and FIGS 11a and 11b.

*Tissue strength*: the vagina naturally weakens with age (98). Surgical excision and stretching of the residual vagina also potentially weakens it (98). A double flap technique “double-breasting” (cf part IV), with diathermy to the superficial epithelium of

the underlying layer, is a useful technique for avoiding tissue excision, repairing a herniation (cystocele, rectocele, enterocele), and, at the same time, bolstering the strength of the vagina. Used in the definitive version of our slingplasty procedure (cf part IV), it provides great strength to the vagina underlying the urethra, and, at the same time, appears to largely prevent “visco-elastic creep”.

*Tissue elasticity* : this is a store of energy (93) (99). If excessive vagina is excised, the remaining tissue is stretched against the restorative force inherent in the vaginal tissue. This may cause the sutures to tear out, especially if subjected to an additional force such as a coughing fit.

*Visco-elastic creep*: even though there may be sufficient tensioning of vagina at the time of operation, subsequent loosening may occur due to visco-elastic creep (93). Using double-breasted flap repairs may prevent “creep” and, at the same time, greatly increase the structural strength below urethra. Such and other alternative techniques based on normal function need to be developed.

*Zone of critical elasticity (ZCE) (FIG 3)*: this must not be over-extended during bladder neck elevation or scarred during vaginal repair, repair of cystocele, etc. Any iatrogenic stretching of vagina, e.g. during bladder neck elevation operations may mechanically fix the vagina’s elasticity at full extension, as per  $ZCE_1$ . At the slightest movement of the pelvic floor, F2 may stretch the vagina to point X, FIG17, rapidly neutralizing F1, so that the urethra cannot be closed. Indeed, it opens on being given the signal to close! (tethered vagina syndrome).

### **Circumstance.**

Excessive tension on the suture lines, e.g. from postoperative vomiting, coughing fits, falls etc. and rarely, haematoma may cause failure, but infection appears to be a rare cause. Repair of one defect may concentrate the intraabdominal pressure/pelvic floor contraction on another subclinically damaged area of vagina, causing it to “blow out”, much in the manner of a perished bicycle tube.

### **The surgeon.**

*Incorrect diagnosis of the causative anatomical defect.* This especially holds for urge symptoms/pelvic pain, which are often caused by a posterior fornix defect. There may exist more than one anatomical defect. or even part of one, e.g. the anterior half of the suburethral vagina may be lax, whereas the posterior part may be intact.

*Hysterectomy* : suturing the vaginal vault from side to side, or by a purse string suture, including fixation of the uterosacral ligaments, would potentially avoid the postoperative appearance of the “posterior fornix syndrome” and the dysfunctions inherent in this syndrome.

*Suburethral scarring* : inappropriate scarring on the posterior surface of urethra may also “tether” the urethra preventing its closure by the periurethral striated muscles. As the periurethral muscles are situated anteriorly, they are unlikely to be affected, We consider that such a “pipe stem” urethra is restorable by dissection of the adhesions and plication of urethra with fine sutures.

*Excessive vaginal tissue excision* : We advise minimal excision of vaginal tissue, especially during repair of cystocele, vault prolapse, etc., as tissue, once excised, cannot be re-created. Excessive tissue excision may cause dyspareunia and the “tethered vagina syndrome”. The dilemma here is that minimal tissue excision with conventional vaginal repairs can lead to subsequent operative failure from visco-elastic creep. Given that such repairs may be performed with minimal disturbance under local anaesthesia, rather than excise excessive tissue at the first operation, it may be preferable to advise the patient that a subsequent tightening may be required. **SURGICAL APPLICATIONS ACCORDING TO THE CLASSIFICATION, FIG 2.**

### **Defect 1 suburethral vaginal laxity.**

*Adequate elasticity must be maintained in the vagina; the vaginal axis must not be altered during suprapubic incontinence procedures, anchoring, not elevation of urethra being the important factor.*

In its pure form with an intact (PUL), suburethral laxity is curable by simple tightening of the suburethral vagina. Performed on an unselected group of patients, success rate was less than 50% (1) (p41-42). Routine excision of a fairly large wedge of anterior vaginal wall has evolved historically, in order to anchor the urethra. Such operations rely solely on the inherent structural strength of vagina to support the urethra. *Because of the requirement for elasticity in its structure, the vagina cannot on its own account provide a structural support if the (PUL) is deficient. Such support is the function of a ligament.* Therefore there should be no other expectation from a vaginal repair than to restore the urethral closure mechanism.

Improvements to vaginal repair technique incorporating a reconstruction of the pubourethral ligaments (PUL), (1 p57) have been devised.

Even with creation of the (PUL) support, inadequate excision of vagina may result in recurrence of incontinence in up to 1/3 of patients because of “visco-elastic creep”. Continence may be restored in these patients by further tightening of vagina.

### **Incompetent urethra.**

We have previously described how the function of the smooth muscle sphincters of urethra is secondary to its insertion points in the vagina. Thus a lax vagina may predispose to a widened urethra. We have demonstrated on many occasions that opening the two vaginal wall flaps during the vaginal part of the IVS operation may result in uncontrollable urinary leakage, demonstrating the importance of the urethral closure mechanism.

*Vaginal repair versus bladder neck elevation.* ( see also above) Simply re-creating the pubo-urethral ligament cured only 50% of patients with stress incontinence (1) (p53-59). Both suburethral tightening of the vaginal hammock (1) (p41-42), and the creation of pubo-urethral ligaments are equivalently important, and need to be performed to cure most patients. Formation of an artificial pubourethral ligament by the IVS technique (cf part IV), is a very simple local anaesthetic technique which rarely fails structurally. Tightening the suburethral vagina to

the precise tension necessary to restore urethral closure without complications is far more difficult (cf section IV).

### **Defect 2) - Tethered vagina syndrome.**

*Surgical stretching of vagina alters both elasticity and tissue strength (94,95). Vaginal and incontinence surgery cannot be carried out in a vacuum, without consideration for the future effects of scarring and ageing on the vaginal tissue structures.* Ageing narrows the margin of elasticity for surgery due to loss of elasticity in the vagina. The importance of elasticity can be visually assessed by comparing FIG 7a (elastic) with FIG 7b, (non-elastic), and also, FIG 11a with FIG 11b. Except for FIG 7a, there is very little movement in the vagina in the region of the pubourethral ligament, point A.

We have seen recurrence of incontinence 15 or 20 years after successful incontinence surgery. We attribute this to age-related changes in the connective tissue of the vagina, particularly matrix, collagen and elastin components. Restoration of elasticity by I-plasty, a type of Z-plasty, has been used successfully by us (1) (p63-67). *Failure of this operation will occur if there is a net deficit of vaginal tissue in the anterior vaginal wall.* We have cured 12/16 largely failed I-plasty patients (68) with application of a free graft in the “zce”, thereby restoring elasticity in the bladder neck area of vagina.

### **Defects 3 & 5) - pubourethral ligament (PUL)/ defective insertion of vagina into pubococcygeus muscle.**

These are the most serious defects as they invalidate the urethral closure mechanism. Point “A”, FIGS 7a, 7b, performs its fulcrum function far below the bladder neck. The Intravaginal Slingplasty (IVS) (cf part IV) procedure works very well with the creation of an artificial ligament directly behind the pubic symphysis, (1) (p56). Zacharin, (109) has developed a successful operation based on inserting a ribbon of rectus sheath in the position of the pubourethral ligament.

It is important to emphasize that operations that anchor the vagina in the region of bladder neck potentially inhibit extension of that part of ZCE between PUL and bladder neck, constituting

approximately 50% of the zone of critical elasticity (ZCE). It is not surprising that postoperative urinary retention and difficulties with bladder emptying occur so frequently with such operations.

Our intravaginal slingplasty operation (IVS), often performed without its vaginal component, has cured also young females of symptoms such as urge incontinence, nocturnal enuresis, faecal incontinence, difficulty in evacuating the rectum, symptoms present since childhood. This has led us to believe that defects 3 & 5 may also occur as congenital defects possibly causing nocturnal enuresis, and that the pubourethral ligament (PUL) also has an important role in ano-rectal opening and closure.

#### **Defect 4) - posterior fornix.**

The process of bladder neck opening requires co-ordinated simultaneous contraction of the rectum and vagina, best seen in FIG 12b, so as to enable the bladder neck to be pulled open. There must be no laxity between anterior wall of rectum and posterior wall of vagina, i.e. a high rectocele, if present, also needs to be corrected, along with any enterocoele, or laxity in the uterosacral ligaments. Careful comparison between FIGS 12a and 12b demonstrates that the fulcrum for angulation of the levator plate is actually the coccyx itself, which also angulates downwards. This indicates that LMA pulls against the whole length of the uterosacral ligament (USL). *This implies pre-existing laxity of the USL between rectum and coccyx may not be correctible by a posterior fornix repair in all cases, something consistent with our clinical experience (cf part IV).* It is possible to re-create the USL using the special tunneller to insert special removable tapes (unpublished data).

*Hysterectomy and residual urine* - transverse suturing of the vaginal vault (1) (p71), may cause incomplete bladder emptying, and other aspects of the posterior fornix syndrome. Suturing the vaginal vault longitudinally, or with a purse string suture provides a stronger anatomical support for the vaginal vault.

In a study of 163 patients presenting with urinary incontinence, 59 gave a history of having had a prior hysterectomy. A highly significant association was

noted between a prior history of hysterectomy with high residual urine\* ( $p = 0.0042$ ); also between high residual urine and "abnormal bladder neck opening" symptoms ( $p = 0.0003$ ) (unpublished observations). The results confirm that hysterectomy may cause abnormalities in bladder neck opening, and that high residual urine may derive from abnormal bladder neck opening. Both may be related to laxity in the uterosacral ligaments.

\* >50 mls.

*Congenital posterior fornix defect.* We have seen lax and separated uterosacral ligaments causing stress and urge incontinence in nulliparous females. Often the symptoms are worse prior to and during periods. This we attribute to the action of hormones and prostaglandins on the cardinal and uterosacral ligaments (91).

#### **Conclusions and future problems to be solved.**

*Which defect?* We use our structured questionnaire, Appendix A, and characteristic clinical, radiological and urodynamic criteria as described to diagnose defects 1-6. *A particular diagnostic criterion can never be infallible, because of the modifying impact of other structures, some of which have been detailed.*

*Quality of the tissues?* Pre-operative use of a more sophisticated elastometer than in FIG 19b, should give vital information about the tethered vagina syndrome, and vaginal elasticity. Extensive studies will be necessary to correlate vaginal elasticity with tissue strength, and then to relate this data with surgical outcome. Because we suspect that the tissue strength may vary in different parts of the anterior vaginal wall, it may be necessary to perform flaps, which still has to be performed as indicated in FIGS 1,2 &3. FIG5 "Cross-over free tapes" The tapes are crossed directly below the urethra, taking care that they are situated well forward of the mid-urethra. They are tied superiorly ONLY with No1 Vicryl, and left entirely free at the vaginal level. This ensures that there can be no injury to the urethra. T = tape; U = urethra; V = vagina; M = rectus muscle. **Conclusion** Use of tension sutures appeared to cause pain, especially if tied too tightly. Analysis of this

surgical variation with regard to the normal anatomy (1) indicates that attachment paraurethrally or to the urethra itself would better re-create the dense fibrous tissue attachment of urethra to vagina. Attachment in the manner of FIG 4 is already being performed. Preliminary results (unpublished data) are most optimistic, indicating that the vagina is firmly attached, without post-operative pain. However, we have found that there is a much greater possibility of post-operative urinary retention, especially if the attaching sutures proceed beyond mid-urethra. Experience using the permanent sling suggest that a “cross-over” method of tape insertion in the “free tapes” version of this procedure, FIG5, would give most of the advantages of a permanent sling. Preliminary results again appear to be optimistic.

Postscript As a general comment, many patients whom we had regarded as being total operative failures with the IVS IV, V and VI versions subsequently reported a significant improvement in their stress incontinence symptoms( unpublished data). We attribute this to the tightening which would result from scar tissue contraction around the double flap repair, a result of inter and intramolecular cross-bonding.

REFERENCE Krantz KE. Anatomy of the urethra and anterior vaginal wall. American J. Obstet Gynecol. (1950), 62:374-386.

**REFERENCES for PART I**

- (1) Petros PE and Ulmsten U. An Integral Theory of Female Urinary Incontinence. *Acta Scand O&G.* (1990), Supplementum No 153, Vol 69:1-79.
- (2) Jeffcoate TNA and Roberts H. Observations on stress incontinence of urine. *J Obst. Gynaecol. Brit. Emp.* (1952), 721-738.
- (3) Bailey KV. Clinical investigation into uterine prolapse with stress incontinence: treatment by modified Manchester colporaphy. *Journal of Obstetrics & Gynaecology of the British Emp. Part II,* (1956), 63:663-676.
- (4) Green TH. Development of a plan for the diagnosis and treatment of urinary stress incontinence. *American J Obstet. Gynecol.* (1962), 83:632-638.
- (5) Lapidés J, Ajemian EP, Stewart BH, et al. Physiopathology of stress incontinence. *Surg. Gynecol. and Obstet.* (1960), 3:224-231.
- (6) Hodgkinson CP. Recurrent stress urinary incontinence. 1978, *American J Obstet. Gynecol.* (1978), 132:844-60.
- (7) Hutch J A. A new theory of the anatomy of the internal urinary sphincter and the physiology of micturition. V The base plate and stress incontinence. *American Journal of Obstets & Gynecol.* (1966), 96-182.
- (8) Olesen KP. Bladder base insufficiency. *Urol Int.* (1975), 30:46-53.
- (9) Krantz KE. Anatomy of the urethra and anterior vaginal wall. *American J. Obstet Gynecol.* (1950), 62:374-386.
- (10) Zacharin RF. The suspensory mechanism of the female urethra. *Journal Anat.* (1963), 97:423-427.
- (11) Richardson AC, Edmonds PB and Williams NL. Treatment of stress incontinence due to a paravaginal fascial defect. *Obst. Gynecol.* (1980), 57,3:357-362.
- (12) Baden WF and Walker TA. Urinary stress incontinence: Evolution of paravaginal repair. *The Female Patient.* (1987), 89-105.
- (13) Summitt RL Jr, Bent AE and Ostergard DR. The pathophysiology of genuine stress incontinence. *Int Urogynecol J.* (1990), 1:12-18.
- (14) Enhorning G. Simultaneous recording of intravesical and intraurethral pressure. *Acta Chir. Scand.* (1967), 30:309-317.
- (15) Constantinou C and Govan H. Contribution and timing of transmitted and generated pressure components in the female urethra. *Female Incontinence,* (1981), Alan R Liss New York, 113-120.
- (16) Greenwald SW, Thorbury JR, and Dunn LJ. Cystourethrography as an aid in stress incontinence. *Obstet. Gynecol.* (1967), 29:324-327.
- (17) Kelly HK and Dumm W. Urinary incontinence in women without manifest injury to the bladder. *Surgery, Gynecology and Obstetric* 1914; 18:444-450.
- (18) International Continence Society. (Abrams P, Blaivas J, Stanton S and Andersen J). Standardisation of Terminology of Lower Urinary Tract Function. *Scand J. Urol Nephrol.* (1988), Suppl. 114.
- (19) Bates CP, Whiteside BM and Turner-Warwick R. Synchronous cine/pressure/flow/cystourethrography with special reference to stress and urge incontinence. *Br. J. Urology* (1970). 42, 714-723.
- (20) Guyon S. Note Sur La Sensibilite De La Vessee AL'etat Normal Et Pathologique. (1887) *Annals Des Maladies Des Organes Genito-urinaires.*
- (21) Barrington FJ. The relation of the hind-brain to micturition. *Brain,* (1921), 44:23-53.
- (22) Fernsides EG. The innervation of the bladder and urethra brain 40, (1918), 149-186.
- (23) Rose DK. Determination of bladder pressure with the cystometer. *JAMA* (1927) 88, 3:151-157.
- (24) Parker MM and DK Rose. Inhibition of the bladder. *Arch. Surg.* 34 (1937) 828-838.
- (25) Denny-Brown D and Robertson GE. On the physiology of micturition. *Brain.* 56, 149-190 (1933).
- (26) Rehfisch (1897) as quoted by Denny-Brown (1933).
- (27) Adler - as quoted by Denny-Brown (1933).
- (28) Le Gros Clarke F. (1883) as quoted by Denny-Brown (1933).
- (29) Mueller LR. (1931) quoted by Denny-Brown (1933).
- (30) Lapidés J, Ajemian EP, Stewart BH, et al. Physiopathology of stress incontinence. *Surg. Gynecol. and Obstet.* (1960), 3:224-231.

- (31) Hodgkinson CP. Recurrent stress urinary incontinence. *American Journal Obstets & Gynecol*, (1978), 132:844-860.
- (32) Youssef AF. Investigation of Sphincter Incontinence of Urine. Charles F. Thomas Springfield Illinois. (1960) 329-369.
- (33) Ingelman-Sundberg A. Urinary incontinence in women excluding fistulas. *Acta Obstet. Gynaecol. Scand.* (1952), 31: 266-291.
- (34) Stanton SL, Cardozo L, Williams J, Ritchie D, Allan V. (1978). Clinical and Urodynamic Factors of Failed Incontinence Surgery in the Female. *Obstet. Gynecol.* 51:515-520 (1978).
- (35) Stanton SL. Colposuspension, in *Surgery of female Incontinence*, EDS Stanton SL and Tanagho EA, Springer - Verlag, Berlin (1986), pp 95-103.
- (36) Cardozo LD and Stanton SL. Genuine stress incontinence and detrusor instability - a review of 200 patients. *Brit Journ Obstets & Gynaecol* 87:184, 1980.)
- (37) Bent AE. Current Genuine Stress Incontinence & Detrusor Instability *International Urogynecological Journ.* (1990) 1:128-131
- (38) Milani R, Scilambrino S, Quadri G, Algeri M. et al. Marshall Marchetti Transprocedure and Burch Colposuspension. In *The Surgical Treatment Of Mild Urinary Incontinence*. *Brit Journ Obstets Gynaecol.* (1985);92:1050-1053.
- (39) Beck RP, Arnus CHD and King C. Results In Testing 210 Patients With Detrusor Overactivity Incontinence Of Urine. *American Journ Obstets. Gynecol.* (1976), 125:593-596
- (40) McGuire EJ and Sevastano JA. Stress Incontinence & Detrusor Instability/Urge Incontinence. *Neurourol. Urodynamics.* (1985);4:313-316.
- (41) Meyhoff HH et al. Incontinence surgery in females with motor urge incontinence, *Proc. Int. Cont. Soc.* 10:109-112 (1980).
- (42) Torrens MJ. A critique of urodynamics, in *Urodynamics*, Eds Mundy AR, Stephenson TP, Wein AJ, Churchill Livingstone, London 1984, 62-68.
- (43) Cantor TJ and Bates CP. A comparative study of symptoms and objective urodynamic findings in 214 incontinent women, *Br J Obstet. Gynaecol.* (1980) 87:889-892.
- (44) Sand PK, Hill RC and Ostegard R. Incontinence History As A Predictor Of Detrusor Instability. *Obstet. Gynecol.* 88;71:257-259.
- (45) Webster GD, Cihelnik SA and Stone AR, Female urinary incontinence; the incidence identification and characterists of detrusor instability. *Neurourol. Urodyn* 1984, 3:235-242.
- (46) Abrams PH, Stanton SL. Idiopathic Bladder Instability Treated By Biofeedback. *Brit Journ Urol.* 1978;50:521.
- (47) Ostergard DR. Office Evaluation Of The Incontinent Female In: Ostergard DR Editor *Symposium On Gynaecological Urology 1984*. New York: Nossau County Medical Center, 1984; P1-50.
- (48) Wein AJ. The pitfalls of urodynamics in Urodynamics (1984) Editors Mundy AR, Stephenson TP & Wein AJ. 150-161.
- (49) ICS First Report. Bates P, Bradley WE, Glen E. et al. *First Report On The Standardisation Of Terminology Of Lower Urinary Tract Function.* *Brit Journ of Urology* (1976), 48:39-42
- (50) Susset JG. Urodynamics Society Presidential Address: Urodynamics - A Step Toward Experimental Urology. *Neurourology & Urodynamics* 4:157-160 (1985).
- (51) Petros PE and Ulmsten U. Urge incontinence history is an accurate predictor of urge incontinence *Acta Obst Gynaecol Scand* (1992), 71:537-539.
- (52) Ulmsten U, Asmussen M and Lindstrom K. A new technique for simultaneous uethrocystometry and measurements of the urethral pressure profile. *Urol Int.* 32:88, (1977).
- (53) Tanagho EA. The anatomy and physiology of micturition, *Clinics in Obstetrics and Gynaecology.* 5:1, 3-25, 1978.
- (54) Petros PE and Ulmsten U. Bladder instability in women: a premature activation of the micturition reflex. *Neurourol. and Urodynamics* -12 : 235-239 (1993).
- (55) Barrow J. *Theories Of Everything. The Quest For Ultimate Explanations.* Oxford University Press. Oxford (1991) 11
- (56) Davies SP. (1992) Simon & Schuster. London. *The Mind Of God.* 136.
- (57) Feneley RCL and Harrison SCW. Urinary continence and micturition. *Colpoproctology and the Pelvic Floor.* (1992), Eds Henry MM and Swash M, Butterworth Heinemann 2nd Ed. 98-111.

- (58) Aranda B & Letzt-Ribink P. Effect of voluntary attention on urethral pressure. *Neurourol & Urodynam.* (1991), 10:571-578.
- (59) Popper KR. A Survey of some fundamental problems. On the problem of a theory of scientific method. Theories. Falsifiability. The problem of the empirical basis. Degrees of testibility. Simplicity. *The Logic of Scientific Discovery.* (1980), Unwin, Hyman, London, 27-146.
- (60) Tanagho EA. Colpocystourethropexy, the way we do it. *Journal of Urology*, (1976), 116:751.
- (61) De Lancey J. Correlative Study of Paraurethral Anatomy. *Obstet. Gynecol.* (1986), 68:91-97.
- (62) Huisman AB. Aspects on the anatomy of the female urethra with special relation to urinary continence. *Clinics in Obstets. and Gynecol.* (1983), Karger Basel, 10:1-31.
- (63) Gosling J. Structure of the lower urinary tract and pelvic floor, in *clinics in Obstet. and Gynaecol.* 12, 2:285-295. WB Saunders CO, London, (1985).
- (64) Kennedy WT. Urinary incontinence relieved by restoration and maintenance of the normal position of urethra, *Amer. J. Obstets. and Gynecol.* 41, 16-28, (1948).
- (65) Turner-Warwick R. Observations of the function and dysfunction of the sphincter and detrusor mechanisms. *Urol. Clin. of North America*, (1979), 6,1:13-30.
- (66) Courtney H. Anatomy of the pelvic diaphragm and ano-rectal musculature as related to sphincter preservation in ano-rectal surgery. *Amer. J. Surgery*, 79:155-173 (1950).
- (67) Shafik A. A new concept of the anatomy of the anal sphincter mechanism and the physiology of the defaecation. II Anatomy of the levator ani muscle with special reference to pubo-rectalis. *Investigative Urol.* (1975), Vol 13, 3:175-182.
- (68) Petros P and Ulmsten U. The free graft procedure for cure of the tethered vagina syndrome - this issue.
- (69) Hastwell GB. Psychogenic pelvic pain or the Occult Prolapse Syndrome. *Medical Journal of Australia.* (1986), 144:405-407.
- (70) Swash M, Henry MM, and Snooks SJ. Unifying concept of pelvic floor disorders and incontinence. *Journal of the Royal Society of Medicine*, (1985), 78:906-911.
- (71) Keele CA and Neil E. The autonomic nervous system. *Samson Wright's Physiology*, (1971), 12th Ed, Eds Keele CA and Neil E, Oxford Uni Press, London. 383-396.
- (72) Creed K. Functional diversity of smooth muscle. *British Med. Bulletin*, (1979), 3:243-247
- (73) Griffiths DJ. Assessment of detrusor contraction strength or
- (74) Constantinou CE. Contraction strength variance during pressure/ flow studies. *Neurourol. and Urodynamics*, (1991), 10:47-52.
- (75) Groen J, Bosch R, and van Mastricht R. *Neurourol. and Urodynamics*, (1991), No 4, Vol 10:332-333.
- (76) Petros PE and Ulmsten U, tests for detrusor instability in women measure the urethral resistance created mainly by pelvic floor contraction as a reaction to premature activation of the micturition reflex, *Acta Obstet Gynecol Scand* ( in press) 1993.
- (76a) Petros PE Doctorate Thesis : Detrusor Instability \_ a Critical Analysis, University of Uppsala, Sweden 1993.
- (77) Blaivas JG, Sinha PH, Zayed AAH and Labib KL. Detrusor - external sphincter dyssynergia. *Journal Urol.* (1981), 125: 542-544.
- (78) Blaivas JG, Labib KB, Bauer SB, and Retik AB. A new approach to electromyography of the external anal sphincter *Journal Urol.* (1981), 117: 773-777.
- (79) Aranda B and Letzt-Ribinik P. Effect of voluntary attention on urethral pressure. *Neurourol. and Urod.* (1991), 10:571-578.
- (80) Paramore RH. Some further considerations on the supports of the female pelvic viscera, in which the intraabdominal pressure is still further defined. *Journal of Obst and Gynaec. Br, Empire*, (1908), 14: 172-187.
- (81) Sturmdorf A. *Gynoplastic Technology.* Philadelphia: Davis, (1919), 109-114.
- (82) Power RMH. Embryological development of the levator ani muscle *Amer. J Obstet. and Gynecol.* 55;3:367-380, (1948).
- (83) Francis WJA. Disturbance of bladder function in relation to pregnancy. *Journal Obstet Gynecol. British Empire.* (1960), 67:353-366.



- (84) Cutner A, Cardozo LD and Bennes CJ. Assessment of urinary symptoms in the second half of pregnancy. *International Urogynecol. Journal*, (1992), 3:30-32.
- (85) Ulmsten U. & Ueland K. The forces of labour. *Clinical Obstets & Gynaecol* (1983) 26:1-108.
- (86) Nemir A and Middleton R. Stress incontinence in young nulliparous women. *Amer. J. Obstet. Gynecol.* (1954) 68: 1166-1168.
- (87) Johnstone TB, Whillis J. Introductory myology. *Gray's Anatomy 31st Edition*. (1954), Eds. Longmans, Green & Co, London, 534-538.
- (88) Goff BH. Secondary reconstruction of damaged pelvic floor, practical consideration of the damaged pelvic floor with the technique for its secondary reconstruction. *Surgery Obstets. & Gynecol.* (1928), 46:855-866.
- (89) Hukins WL and Aspden RM. Composition and properties of connective tissues, *Trends in biochemical sciences*, (1985) 7,10: 260-264.
- (90) Nordin M. Biomechanics of collagenous tissues, in *Basic Bomechanics of the Skeletal System*. (1980), Eds, Frankel VH & Nordin M., Lee & Febiger, Philadelphia. P87-110.
- (91) Ulbjerg N & Ulmsten U. The Physiology Of Cervical Ripening and Cervical Dilatation and the Effect of Abortefficient Drugs, in *Medical Induction of Abortion*. Baillere's Clinical Obstetrics and Gynaecology, (1990), Editor M Bygdeman, Baillere's Tindall, London. 263-281.
- (92) Downing J & Sherwood OD. The physiological role of relaxant in the pregnant rat - the effect of cervical collagen & glycosaminoglycans. *Endocrinology*. (1986), 118, 2:471-479.
- (93) Thonar EJMA & Kuettner KE. Biochemical basis of age related changes in proteoglycans. *Biology of Protoeglycans*. (1987), Editors Wight TN & Mecham RP, Academic Press Inc. P211-246.
- (94) Yamada H. Mechanical properties of urogenital organs and tissues in *Strength of Biological Materials*, (1970), Williams & Wilkins Co, Baltimore. Ed Evans FG. 205-218.
- (95) Yamada H. Aging rate for the strength of human organs and tissues. *Strength of biological materials*. (1970), Williams & Wilkins Co, Baltimore. Ed Evans FG. 272-280.
- (96) Peacock EE. Structure, synthesis and interaction of fibrous protein and matrix. *Wound Repair*. (1984), 3rd Edition, Publishers WB Saunders Co, Philadelphia. 56-101
- (97) Yamauchi M, Woodley DT and Mechanic GL. Aging and cross-linking of skin collagen. *Biochemical and Biophysical Research Communications*. (1988), 152, 2:898-901.
- (98) Bailey AJ, Ranta MH, Nicholls AC, Partridge SM and Elsdon D. Isolation of alpha amino adipic acid from mature dermal collagen and elastin. Evidence for an oxidative pathway in the maturation of collagen and elastin. *Biochem. & Biophysical Research Communications*. (1977), 78, 4:1403-1409.
- (99) Lose LG. Study of Urethral Closure Function in Healthy and Stress Incontinent Women. *Neurology and Urodynamics*, (1992) 11:55-89.
- (100) Hill AV. The Heat of Shortening and the Dynamic Constance of Muscle *Proceedings of Royal Society of London* (1938) B 126: 136-195.
- (101) Constantinou CE. Resting and stress urethral pressures as a clinical guide to the mechanism of continence. *Clinics in Obstets & Gynecol*, (1985), 12, 2:343-356.
- (102) Tanagho EA and Stoller ML. *Urodynamics: Uroflowmetry and female voiding patterns*. *Urogynecology and Urodynamics Theory and Practice*, (1991), 3rd ed. Eds. Ostergard D and Bent AE. 164-170.
- (103) Spencer JR, O'Connor Jr. VJ and Schaffer AJ. A Comparison of Endoscopic Suspension of the vesical neck with suprapubic vesicourethropexy for treatment of stress in urinary incontinence. *Journal of Urology* 1978; 137:411-415.
- (104) Zacharin RF. Abdominoperineal urethral suspension in the management of recurrent stress incontinence of urine. *Obstet. Gynecol.* (1983), 62:644-654.

## APPENDIX A

## PATIENT QUESTIONNAIRE

NAME :  
ADDRESS :

TELEPHONE :

DATE: \_\_\_\_\_

DATE OF BIRTH :

WEIGHT :

NO. OF VAGINAL DELIVERIES ( )

NO. OF CAESAREAN SECTIONS ( )

**DESCRIBE IN YOUR OWN WORDS YOUR MAIN URINARY SYMPTOMS AND DURATION:****ALL SECTIONS : TICK APPROPRIATE SQUARE ( ). Write extra details if you wish****S.I. SYMPTOMS**

	YES	NO	50%or more
DO YOU LOSE URINE DURING:			
SNEEZING	( )	( )	( )
COUGHING	( )	( )	( )
EXERCISE	( )	( )	( )
LAUGHING	( )	( )	( )
(1*) WALKING	( )	( )	( )
(2*) PICKING UP OBJECTS OFF THE FLOOR	( )	( )	( )

**SYMPTOMS OF DEFICIENT EMPTYING**

(3*) DO YOU FEEL THAT YOUR BLADDER DOESN'T EMPTY PROPERLY?	( )	( )	( )
(3*) DO YOU EVER HAVE DIFFICULTY STARTING OFF YOUR STREAM?	( )	( )	( )
(3*) IS IT A SLOW STREAM?	( )	( )	( )
(3*) DOES IT STOP AND START INVOLUNTARILY?	( )	( )	( )

**VOLUNTARY "CUT-OFF"**

(4*) CAN YOU INTERRUPT YOUR STREAM?	( )	( )	( )
-------------------------------------	-----	-----	-----

**URGE SYMPTOMS:**

DO YOU EVER HAVE AN UNCONTROLLABLE DESIRE TO PASS URINE?	( )	( )	( )
IF SO, DO YOU EVER WET BEFORE REACHING A TOILET?	( )	( )	( )
DO YOU FEEL URGENCY WHILE WASHING YOUR HANDS OR SHOWERING?	( )	( )	( )
(5*) DO YOU HAVE PAIN WHILE PASSING URINE?	( )	( )	( )
(6*) IN THE MORNING DO YOU WET BEFORE REACHING THE TOILET?	( )	( )	( )
HOW MANY TIMES DURING THE NIGHT DO YOU GET UP TO PASS URINE? -		write number	( )
HOW MANY TIMES DO YOU PASS URINE DURING THE DAY? -		write number	( )
DID YOU WET THE BED AS A CHILD? YES / NO			

**BOWEL SYMPTOMS:**

- (7a\*) DO YOU HAVE PROBLEMS EMPTYING YOUR BOWELS? YES / NO
- (7b\*) DO YOU EVER SOIL YOURSELF (FAECES)? YES / NO
- DO YOU HAVE ANY OTHER BOWEL PROBLEMS? ( DESCRIBE)

**SOCIAL INCONVENIENCE:**

- (8\*) ARE YOU “MOIST” ALL THE TIME? YES / NO
- (9\*) DO YOU LEAVE PUDDLES ON THE FLOOR? YES / NO
- DO YOU LOSE URINE IN BED AT NIGHT? YES / NO
- DO YOU HAVE TO WEAR A PAD ON GOING OUT NEVER /SOMETIMES /ALWAYS

**PREVIOUS OPERATIONS:**

- (10\*) HAVE YOU HAD A HYSTERECTOMY OR VAGINAL REPAIR (CIRCLE WHICH)? when? \_\_\_\_\_ / NO
- (11\*) HAVE YOU HAD PREVIOUS SURGERY FOR YOUR INCONTINENCE? when? \_\_\_\_\_ / NO
- ARE YOU better OR worse SINCE? (CIRCLE WHICH)
- (12\*) HAVE YOU HAD AN “ ANAL STRETCH” OR HAEMORRHOIDECTOMY? when ? \_\_\_\_\_ / NO
- |  | YES | NO  | 50%or more |
|--|-----|-----|------------|
| (13*) <b>PELVIC PAIN :</b>                                 |     |     |            |
| DO YOU HAVE DEEP PAIN ON INTERCOURSE? ( )                  | ( ) | ( ) | ( )        |
| DO YOU HAVE A PAIN DOWN AT THE BOTTOM OF YOUR SPINE? ( )   | ( ) | ( ) | ( )        |
| DO YOU HAVE A PAIN DOWN AT THE BOTTOM OF YOUR ABDOMEN? ( ) | ( ) | ( ) | ( )        |
| DO YOU FEEL TIRED AND IRRITABLE AT THE END OF THE DAY? ( ) | ( ) | ( ) | ( )        |

**SECTION BELOW\*\* FOR OFFICE USE ONLY ( CONCLUSIONS / SUGGESTED DIAGNOSIS)**

\* ASTERISK DENOTES THAT A PARTICULAR SYMPTOM MAY BE FREQUENTLY FOUND WITH A PARTICULAR CONDITION

- 1\* — low MUP with too loose or too tight SLV.
- 2\* — if this is the only SI symptom, it is termed “paradoxical leakage”, and must exclude tethered vagina syndrome in patients with previous vaginal surgery.
- 3\* — USL, SLV, posterior vaginal wall laxity, but also after excessive bladder neck elevation .
- 4\* — voluntary closure mechanism defective per se , but generally found in more major defects, e.g. PUL
- 5\* — exclude UTI, chlamydia, etc.
- 6\* — tethered vagina with previous operation, but also PUL defect with no previous operation.
- 7a\* — may be due to defective PUL and /or rectocele.
- 7b\* — defective PUL and /or anal mucosal prolapse ( descending perineal syndrome).
- 8\* — low MUP / usually with lax suburethral vagina or tethered vagina syndrome.
- 9\* — denotes defective PUL, but may be also due to defective CT “glue” between vagina/PCM.
- 10\* — must exclude USL defect.
- 11\* — must exclude tethered vagina syndrome in patients without previous hysterectomy.
- 12\* — possible torn external anal sphincter.
- 13\* — USL defect.

\*\* © Copyright

Petros/Ulmsten

## APPENDIX B

*Force generated by the pubococcygeus muscle, FIG 23.*

The pubococcygeus muscle generates a constant force (F1) for a given stimulus (98).  $Force = M \times a$  where M= mass and a = acceleration. If M increases (higher urine volume), 'a' decreases, as does the terminal velocity of the contracting muscle. If the vagina is loose, some of the muscle force generated may not be transmitted, as X, may not be reached.

*Work generated by pubococcygeus muscle.*

PCM, FIG 23, must overcome the inertial force of gravity "g" acting on the volume of urine. Calculating from our data, the mean force generated by our patients was  $92/16 \times .109 \times 9.8$  Newtons = 6.14 Newtons, where mass = 109 gms., g = 9.8, and 92/16 represents the inverse of the fractional decrease in CTR. Based on the data from the stress extension curve in FIG 17 (93), the vagina requires to be elongated 80% so as to be able to transmit a contraction without further extension. i.e. a force of 20 gm/sq mm is required. Expressed as Newtons (Kg/sq M):  $.02 \times 100 \times 100 = 200$  Newtons/sq M. Taking the vagina to be a cylinder, 12 cm long, and with a radius of 2 cm, total area of vagina is  $2\pi r \times 12 = 150.8$  sq cm. Taking the area of anterior vagina up to the bladder neck as constituting 1/4 of the total vagina, then the area of vagina effectively being tensioned by the forward movement of pubococcygeus muscle is  $150.8 / 4 = 37.7$  sq cm. Therefore the approximate force needed to stretch the vagina to the point where it has no more elasticity is  $200 \times .0037 = .74$  Newtons. Therefore the total strength of the muscle contraction is  $6.14 + .74 = 6.88$  Newtons#. If it is accepted that the muscle contracts 1.5 cm forwards. The work is therefore  $F \times Dist. = .0992$  Joules.

*Power generated by the pubococcygeus muscle.*

If a cough occurs over 1 second, then the power generated averages out at .0992 W or 99.2 mW. An assumption was made that the tension curve of the rabbit vagina was similar to the human. This is so for rabbit ureter, bladder and trigone, Yamada (93,94).

According to Zacharin, (103) the distance between the insertion point of pubourethral ligament and the symphysis pubis is 1.5 cm in the cadaver. In the live patient (FIG 7a), The distance A-PS is clearly longer than 1.5 cm, so that the power generated would be higher.

# we have made several assumptions; therefore this result is an

approximation only.

## **PART IV: SURGICAL APPLICATIONS OF THE THEORY - DEVELOPMENT OF THE INTRAVAGINAL SLING PLASTY (IVS) PROCEDURE**

*Key words: urinary incontinence; female incontinence surgery;*

Authors: PE PAPA PETROS, MB BS Dr Med Sc MRCOG FRACOG Dept of Gynaecology Royal Perth Hospital Perth, Western Australia and  
U Ulmsten, MD PHD Dept of Obstetrics and Gynaecology Uppsala University Akademiska sjukhuset Uppsala, Sweden

- I. An anatomical basis for success and failure of female incontinence surgery.
- II. The development of the intravaginal slingplasty procedure: IVS II - (with bilateral “tucks”).
- III. Further development of the intravaginal slingplasty procedure: IVS III - (with midline “tuck”).
- IV. Further development of the intravaginal slingplasty procedure: IVS IV - (with “double-breasted” unattached vaginal flap repair and “free” vaginal tapes).
- V. Further development of the intravaginal slingplasty procedure: IVS V - (with “double-breasted” unattached vaginal flap repair and permanent sling).
- VI. The intravaginal slingplasty procedure: IVS VI - (further development of the “double-breasted” vaginal flap repair - attached flap).
- VII. The free graft procedure for cure of the tethered vagina syndrome.
- VIII. The posterior fornix syndrome: A multiple symptom complex of pelvic pain and abnormal urinary symptoms deriving from laxity in the posterior fornix of vagina.

### **FOREWORD**

Our techniques for surgical correction of urinary incontinence are a direct application of the Integral Theory and its biomechanical derivations. Correction of 5 of the 6 causative anatomical defects is described in this section. If the anatomical defects are correctly identified, the techniques described here have been demonstrated to cure stress incontinence, bladder instability, (when the cause is premature activation of the micturition reflex), non-stress non-urge incontinence in the elderly, and “leakage all the time” from urethral incompetence.

Re-creation of the pubourethral ligament, and tightening the suburethral vagina were found to be equally important for cure of stress and urge incontinence (1). Recreation of the pubourethral ligament using the special tunneller rarely fails structurally. The instrument automatically positions the tape in the precise position of the pubourethral ligament. Formation of the artificial pubourethral ligament appears to be adequate using either Teflon

or Mersilene. The development of the IVS operation in the subsequent papers is therefore largely a story of the advantages and disadvantages of various techniques for anatomical correction of suburethral vaginal laxity, how these techniques impact on the biomechanical concepts presented earlier, and how the compromised tissues impact on these techniques. As the tissues are often frail and lacking in elasticity, the operations here described do require a precise surgical technique. An intuitive understanding of vaginal, perivaginal and ligamentous tissues is essential for surgical success using our techniques, as structural strength and elasticity diminish with age, narrowing the margin for error with restorative surgery. The discipline of operating under local anaesthesia greatly enhances the surgeon’s precision and intuitive sensitivity to tissues. Operative failure using this new method is usually associated with:

- a) wrong diagnosis of the causative anatomical defect;

- b) tearing out of sutures
- c) loosening of the vagina by “visco-elastic creep (this may partly re-tighten after 6 months)
- d) scarring at bladder neck (if tissue excision extends beyond bladder neck)
- e) especially in old ladies, decompensation of the tissues in the posterior part of vagina following strengthening of the anterior vagina by the Intravaginal Slingplasty operation.

The first paper in this section deals with some presently existing techniques for surgical treatment of female urinary incontinence interpreted in the light of the Integral Theory. In the subsequent papers, a serial evolution of the IVS procedure is presented. Most of the biomechanical/surgical principles introduced in part III were empirically tested/derived within these procedures. We have found that the more evolved procedures as described in papers IV V and VI work quite properly with high primary success rate. Simultaneously they fulfill the criteria for “simple office procedures”, i.e. the patient is operated under local anaesthesia without postoperative catheterization and early return to daily work. Ongoing randomised prospective studies will hopefully identify which version is to be recommended on which specific occasion.

Finally, it is obvious that this new method centres around the vagina, both theoretically, and surgically. Though we are both gynaecologically trained, **we both believe, unequivocally, that these new techniques should be practised equally by INTERESTED urologists and gynaecologists, both of whom will need to adapt to the new concepts of vaginal conservation.** We do not consider that the actual surgical techniques are difficult to learn. The important thing will be understanding the theory and biomechanics so that proper diagnosis and surgical correction may be made. *Other than correct and precise re-creation of the ligaments\**, the fine points of technique will necessarily depend on the individual surgeon. We suggest that whatever technique is used, the patient must be told that, because of the decompensated nature of the vaginal tissues, failure may occur in up to 20%, so that a subsequent adjustment to the vaginal tension may be necessary.

\* we emphasize the importance of using the special tunneller here.

# AN ANATOMICAL BASIS FOR SUCCESS AND FAILURE OF FEMALE INCONTINENCE SURGERY

PE PAPA PETROS, MB BS Dr Med Sc MRCOG FRACOG Dept of Gynaecology Royal Perth Hospital Perth, Western Australia

and

U Ulmsten, MD PHD Dept of Obstetrics and Gynaecology Uppsala University Akademiska sjukhuset Sweden

## ABSTRACT

The reasons why surgical procedures for cure of stress incontinence succeed and fail are outlined, with special reference to the various anatomical defects in the vagina and its supporting ligaments which may cause defective bladder neck opening and closure.

## INTRODUCTION

This analysis is based on the consideration that it is the tensioned vagina which opens and closes the bladder neck (1), and that laxity in the vagina or its supporting ligaments may cause symptoms of stress incontinence, urge incontinence or inability to initiate micturition.

### In the normal patient

“Resting closed position” (FIG 1). The vagina is suspended anteriorly by the pubourethral ligament (PUL) (2), superiorly by the arcus tendinaeus fasciae pelvis, (3), and posteriorly by the uterosacral ligament (USL) (1). The slow twitch muscle fibres tension the vagina against its supporting ligaments, like the membrane of a drum, pubococcygeus muscle (PCM) pulling the vagina anteriorly, levator plate (LP) posteriorly, and the longitudinal muscle of the anus (LMA) inferiorly.

“Active closed”. Fast twitch contraction forward of (PCM) pulls the two ends of the ascending vagina (Figure 1) tightly around the urethra, closing it off and immobilizing it while (LP) and (LMA) pull the bladder down and back like an elastic balloon, kinking off and closing off the urethra as you would close off a hose. At the same time, the stretched vagina supports the nerve endings (N) at the bladder base. By supporting these nerve endings it prevents the premature activation of the micturition reflex. For these opposite muscle movements to occur, there needs to be sufficient elasticity in the bladder neck area. This is called the “zone of critical elasticity”

(1). Loss of elasticity here may cause the forward movement of vagina to be cancelled out, leaving the bladder neck in the incontinent “open position”, (Figure 1) .

“Open position”.

With bladder neck opening, exactly the same muscle movements occur as in bladder neck closure, except that (PCM) relaxes during opening. As part of the micturition reflex, (PCM) relaxes. This allows (LP) and (LMA) to uninhibitedly pull at (X), opening the bladder base, creating a “funnel”, enlarging the urethral outlet. At the same time, this stimulates the nerve endings (N), activating and reinforcing the micturition reflex.

### In the patient with bladder dysfunction

#### Stress/urge incontinence

may result from laxity in the vagina or its supporting ligaments. Loss of the drum like tensioning may cause defective closure (stress incontinence), or deficient inferior support for the nerve endings (N), leading to premature activation of the micturition reflex, (urge incontinence, or “bladder instability”). It is possible for voluntary contraction of the pelvic floor to reverse this reflex by tensioning the vagina, thus supporting “N” from below (1). Motor urge incontinence is considered to be an end-point of urge incontinence, whereby patients cannot reverse the micturition reflex by upward tension from the voluntary closure mechanism (1).

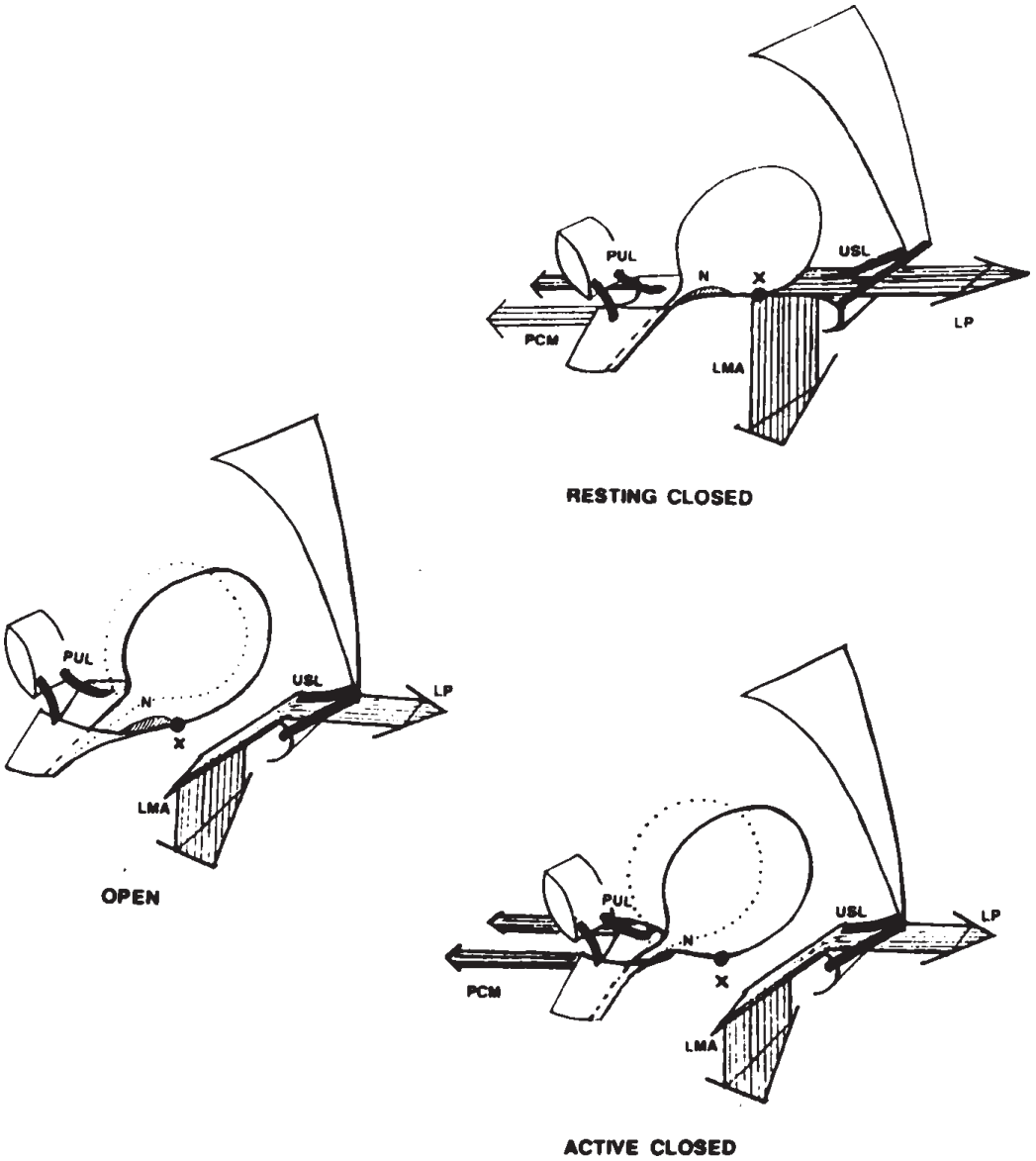

FIG 1

**Bladder neck opening and closure.**

This is a 3 dimensional schematic representation of the bladder and urethra lying inside the anterior vaginal wall ("hammock"). The broad arrows indicate the muscle forces exerted on the anterior vaginal wall, tensioning it like the membrane of a drum.

PUL = pubourethral ligament, USL = uterosacral ligament. "N" = specialized nerve endings at the bladder base, "X" = vesicovaginal ligament, PCM = pubococcygeus muscle, LP = levator plate, LMA = longitudinal muscle of the anus. The broken lines indicate the resting position of the bladder.



### Defective opening

may also result from a lax supralelevator vagina. It may be expressed as difficulty in initiating micturition, stopping and starting, low flow, and high residual urine, due to inability to sufficiently stimulate "N" (1). Laxity in the uterosacral ligaments dissipates the contraction of LMA, FIG1, preventing proper funnelling into the "open" position, and therefore not sufficiently activating the nerve endings "N" so as to initiate micturition. Residual urine may thus be simply an end-point of this inability to open the bladder.

### THE ANATOMY OF SURGICAL SUCCESS AND FAILURE ACCORDING TO (1).

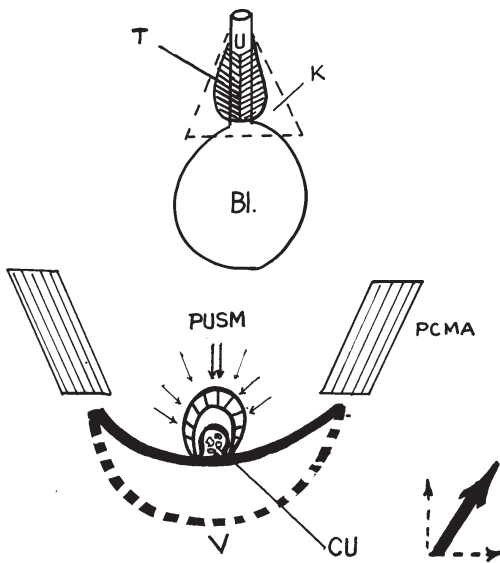

FIG 2

#### Vaginal repair.

Upper diagram: the interrupted lines correspond to the wedge excision (K), Kelly Repair, of the anterior wall of vagina. The vaginal "tuck" procedure is indicated by the cross-hatched area ("T"). Bl = bladder; U = urethra. The lower diagram represents a cross-section taken at the level of the mid-urethra. (PCMA) = pubococcygeus muscle (CU) = cresta urethralis, (PUSM) = periurethral striated muscle. The vector forces from (PCMA) are shown in the bottom right hand corner.

### VAGINAL REPAIR

*Normal urethral closure:* (FIG 2) Contraction of the anterior portion of pubococcygeus muscle (PCMA) pulls the cresta urethralis (CU) towards the periurethral striated muscle (PUSM) by tensioning the vagina (V), at the same time anchoring the insertion of the periurethral striated muscle (PUSM). (PUSM) contraction seals off the urethra.

*Vaginal laxity:* This will not allow the pubococcygeus muscle to create the tympanic membrane to close off the urethra and to allow the bladder neck closure mechanism to operate (FIGS 1, 2). What a vaginal repair does, is take out some of this lax tissue, so that the muscles acting on the vagina can now stretch it sufficiently to close off the urethra (Figure 2 interrupted lines). Therefore, a vaginal repair (Kelly procedure (4)) restores this component of the urethral closure mechanism. It follows that there should not be other expectations of a vaginal repair. The same effect can be achieved by doing a midline incision with a scalpel stopping just short of the bladder neck, dissecting laterally and excising a much smaller segment of vagina ("T", FIG2), and suturing it with horizontal mattress sutures. This procedure is easily performed under local anaesthesia as an office operation. It is possible to prevent postoperative retention in vaginal repair operations by stopping the suburethral incision one centimetre short of the bladder neck. The vaginal repair is an important part of the surgical armamentarium, as it restores the urethral closure mechanism (1).

*Failure of vaginal repair operations.* There may be other anatomical defects, e.g. USL, PUL defects etc., FIG 1. The vaginal repair itself may cause failure. Insufficient tissue may be excised. Alternatively, creation of a rigid scar across the bladder neck may cause the more powerful (LP) and (LMA) muscles to cancel the forward movement of PCM needed for urethral closure (FIG 1). The end result is an open instead of a closed position for bladder neck on effort. This condition has been designated as "the tethered vagina syndrome" (5).

The typical sequence is: as soon as the patient's foot hits the floor, the levator plate has to contract to keep

the intraabdominal contents in place. The forward movement of PCM necessary to close bladder neck is "tethered" by LP FIG 1, the bladder neck remains open and the patient wets all the way to the toilet.

### ABDOMINAL PROCEDURES.

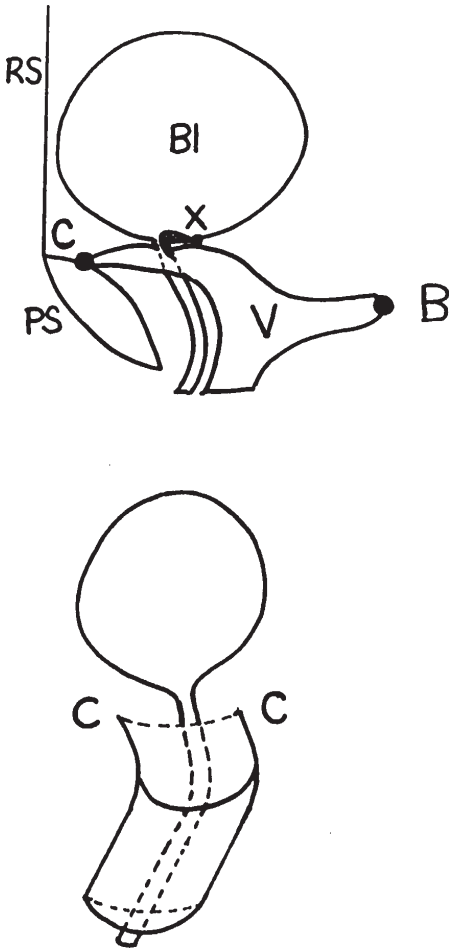

FIG 3

#### Colposuspension operations.

The upper diagram represents a sagittal section of the bladder and vagina in a patient who has had a colposuspension. "C" represents the bony attachment point, and "X" the vaginal attachment point. The lower diagram represents the elevated (stretched) anterior wall of vagina (V) and bladder (B1) viewed from behind, and indicates how elevation can tighten a lax vagina by elongating it. (RS) = Rectos Sheath; (B) = Posterior Fornix; (PS) = Public Symphysis.

**Colposuspension operations** (FIG 3) anchor the proximal urethra by elevating the vagina in the bladder neck region and attaching it directly to the periosteum of the pubic symphysis (6), Coopers Ligament, (7) using a permanently implanted nylon suture either sutured into vagina, (8), or by anchoring it in a square piece of dacron (9). Elevation tightens the suburethral vagina by elongating it and it fixes the bladder neck allowing the bladder neck closure mechanism to operate. If there is sufficient elasticity in the anterior vaginal wall to permit the opposite muscle movements to occur, (FIG 1), these operations work well. If, however, (C-X) is too tight, and the funneling necessary for bladder neck opening, (FIG 1), cannot be achieved, there may be flow defects and urinary retention, sometimes permanent (10). The elevation may also chronically stimulate "N", Fig 1, creating new incidence of urgency in these procedures.

The potential exists for anatomical distortion in this operation. In the long term this may create severe problems, because connective tissue is not a static substance. As concerns the crossbonding of collagen fibrils, it is known that the inter and intramolecular cross-bonding increases with age (11), making the connective tissue less elastic and more brittle. Excessive stretching of old tissues during bladder neck elevation procedures is more liable to rupture the elastin component, causing them to lose much of their structural integrity, resulting in an extreme form of the "tethered vagina syndrome" (1). Operative failure may also occur years later due to age - related loss of elasticity and contraction of scar tissue, again resulting in the tethered vagina syndrome (1). Pulling the vagina upwards may elongate the uterosacral ligaments, accounting for the up to 7.6% incidence of enterocele, (7).

*Use of non-autologous materials and slings.* Nylon and Dacron patches(8) (9), may irritate the tissues to form granulation tissue, discharge and of course chronic suprapubic pain (12).

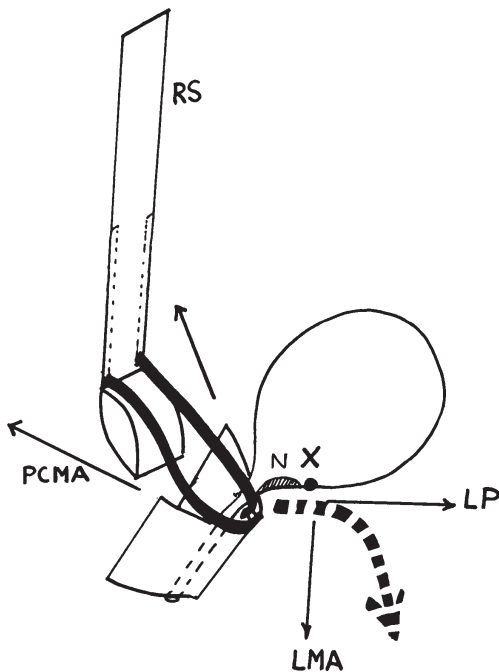

FIG 4

**Sling operations.**

This figure represents a 3 dimensional view of the suburethral vagina and the bladder in an Aldridge Sling operation looked at from behind. Strips of rectus sheath (RS) are configured below the urethra (dark heavy lines). The heavy interrupted arrow represents the vector forces from levator plate (LP), and longitudinal muscle of the anus (LMA). "N" = specialized nerve endings at the bladder base, "X" = vesicovaginal ligament, (PCMA) = anterior portion of pubococcygeus muscle.

**Sling Operations**

The Aldridge sling operation (13), is often used in cases where bladder neck elevation procedures have failed. If a sling is placed as indicated in FIG 4, the bladder neck will be forcibly restrained so that the bladder neck closure mechanism can operate. The proximal urethra is directly immobilized, preventing the activation of "N", FIG 1, and the micturition reflex, permitting cure of uninhibited detrusor contractions (14). Note how the sling provides a fulcrum allowing the (PCMA) to activate the urethral closure mechanism, and (LP) and (LMA) to activate the bladder neck closure mechanism.

However, as the bladder neck is forcibly restrained against involuntary opening, it is also forcibly stopped

from funnelling, FIG 1, during micturition. Therefore, urinary retention, slow flow, and difficulty initiating micturition are common features of these operations (15). These operations require skill, judgment and luck, as subsequent muscle and scar contraction may result in transection of the urethra. Herniation may occur at the site where the fascia has been taken. Using nylon (Zoedler) (15) or dura mater (Lyodura) (15) lessens the dangers of incisional hernia found with the Aldridge operation, but increases the chances of transecting the urethra, especially in unskilled and inexperienced hands.

*Summary of problems with abdominal operations:* they are major procedures with the potentiality for causing haemorrhage, thrombosis, and prolonged hospitalization (10). With a Stamey and Peyrera operations there may be also suprapubic pain. In-dwelling catheterization for several days is a feature as is urinary retention, flow problems, and urgency. The long term failure rate may be as high as 40% according to a comprehensive literature survey (16).

**CORRESPONDENCE:**

P.E.PAPA PETROS  
14A/38 Ranelagh Crescent  
South Perth WA 6151  
Australia  
Fax: 61-9-474 3766

**REFERENCES**

- (1) Petros P and Ulmsten U. An Integral Theory of Female Urinary Incontinence. *Acta Obstet et Gynecol Scand* 1990; Supplementum No 153,69:7-31.
- (2) Zacharin RF. The suspensory mechanism of the female urethra. *J Anat* 1963;97:423-427.
- (3) De Lancey J. Correlative Study of Paraurethral Anatomy. *Obstet. Gynecol.* 1986;68:91-97.
- (4) Kelly HK and Dumm W. Urinary incontinence in women without manifest injury to the bladder. *Surgery, Gynecology and Obstetric* 1914;18:444-450.
- (5) Petros P and Ulmsten U. The tethered vagina syndrome, postsurgical incontinence and I-plasty operation for cure. *Acta Obstet et Gynecol Scand.* 1990; Suppl. No 153, 69:63-67.

- (6) Marshall VF, Marchetti AA and Krantz KE. The correction of stress incontinence by simple vesicourethral suspension, *Surgery Gynecol. and Obstetrics* 1949;88:509-518.
- (7) Burch JC. Cooper's ligament urethrovesical suspension for stress incontinence. *Am. Journal of Obstet. Gynecol.* 1968; 100:764-772.
- (8) Pereyra AJ. A simplified surgical procedure for the correction of stress incontinence in women. *Western Journal of Surgery, Obstetrics and Gynecol.* 1959;67:223-228.
- (9) Stamey TA. Endoscopic suspension of the vesical neck for urinary incontinence in females: report on 203 consecutive patients. *Annals of Surgery* 1980;192:465-471.
- (10) Hodgkinson CP and Stanton SL. *Surgery of Female Incontinence.* Eds. Stanton SL and Tanagho MLA, Springer-Verlag Berlin 1980; 66-67.
- (11) Peacock EE. *Wound Repair.* WB Saunders Co, Phil. 3rd Ed 1984; 99-105.
- (12) Richardson D A, Bent AE, Ostergard DR and Cannon D. Delayed reaction to the Dacron buttress, used in urethroplexy. *Journal of Reproductive Medicine* 1984;29,9:689-692.
- (13) Aldridge AH. Transplantation of fascia for relief of urinary stress incontinence. *Am. J. Obstet. Gynecol.* 1942;44:398-411.
- (14) McGuire EJ and Lytton B. Pubovaginal procedure for stress incontinence. *Journal of Urology* 1978;119:82-84.

# THE DEVELOPMENT OF THE INTRAVAGINAL SLINGPLASTY PROCEDURE: IVS II - (with bilateral “tucks”).

Authors:

PE PAPA PETROS\*, MB BS Dr Med Sc MRCOG FRACOG Dept of Gynaecology Royal Perth Hospital Perth, Western Australia, Dept of Obstetrics and Gynaecology Uppsala University Akademiska sjukhuset Uppsala, Sweden

and

U Ulmsten, MDPHD Dept of Obstetrics and Gynaecology Uppsala University Akademiska sjukhuset Uppsala, Sweden

## ABSTRACT

A new local anaesthetic procedure, the intravaginal slingplasty operation performed with bilateral “tucks” was performed on 39 patients with stress incontinence, and 18 patients with urge incontinence. The operation is performed through a 1-2 cm suprapubic incision and works by creating an artificial pubourethral ligament and by tightening the suburethral vagina. The primary operation cured 64% of 39 patients with stress incontinence, and 90% of 18 patients with urge incontinence. A minor surgical adjustment to the vaginal wall tension in the failed SI group at a later date improved the 15 month success rate to 90%.

This procedure is promising in that it is minimally invasive, does not require postoperative catheterization, and allows return to work within 7-10 days.

The results emphasize the importance of the pubourethral ligament and adequate suburethral vaginal tension for adequate bladder neck closure, and the effect of bladder neck scarring in the causation of urinary incontinence. Further development is required.

## INTRODUCTION

A new ambulatory surgical procedure performed in two stages was recently reported, the Intravaginal Sling Procedure (IVS I), (1). Stage 1 consisted of an adjustable sling operation. This primary procedure cured 50% of patients. Stage 2 was performed on the 50% of patients who failed to be cured by the sling operation, and consisted of tightening of the suburethral vagina by excision of leaf-shaped segments of vaginal epithelium (tucks). This improved the success rate to 82.5%. Both procedures also simultaneously cured pre-existing urge symptoms in almost all patients cured of their stress symptoms. There was no new incidence of urgency.

Experimentally, (2), the Stage 1 operation was shown to accurately create an artificial pubourethral ligament. Radiologically (1) it was shown to support the bladder neck on straining with no post-operative bladder neck elevation, implying that tape insertion

per se, and not elevation by the sling was responsible for return of continence.

On the basis of these results, it was decided to perform the next group of operations where possible, entirely under local anaesthesia/midazolam, and to perform the “tuck” procedure simultaneously with the insertion of the tape.

## PATIENTS MATERIALS AND METHODS

Fifty-seven patients with no previous history of incontinence surgery were referred for treatment of urinary incontinence. Stress incontinence (SI) was objectively the major incontinence problem in 39 patients, whereas urge incontinence symptoms were dominant in the remaining 18 patients. Age ranged from 25 to 72 years (mean 50.5), parity, 1 to 5 (mean 2.5), and weight from 53 to 105 kg (mean 68 kg). In the first instance, all patients had an intravaginal

slingplasty procedure performed, according to Fig 2. Owing to inadequate continence control, 13 patients had a further vaginal adjustment performed between 3 and 6 months after the primary operation. The adjustment aimed to either tighten the suburethral vagina (tuck), or to loosen an excessively tight bladder neck, (I-plasty) (5).

**Diagnostic procedures.** All patients were assessed pre operatively, and where possible postoperatively, with full history (questionnaire and interview), and physical examination, standing lateral x-ray in resting and straining positions, with a dye filled Foley catheter. Exercise pad tests were also carried out, including coughing (x10) and star (scissor) jumps (x10), with 500 mls. instilled methylene blue saline. Urine loss was quantified after each exercise by pad weighing. In addition to the above, supine filling cystometry, urethral pressure profiles, cough transmission ratios, and urodynamic flow/pressure tests were performed. Cure of SI was defined as less than 0.5 gm of urine on pad testing. In the small number of patients who, for different reasons were not objectively tested, anything other than a small occasional urine loss with coughing or sneezing was defined as a failure. Cure of urgency was defined as symptomatic disappearance of urge symptoms, and the objective cure of urge symptoms/urine loss on provocative testing.

**Surgical procedure.** The Intravaginal Slingplasty was performed under local anaesthesia/midazolam. No preoperative antibiotics were used. The patients were placed in the lithotomy position. At least 50 mls of 0.25 prilocaine with 1/200,000 adrenalin, was injected suprapubically into the skin, fascia of the rectus abdominis, and 30-40 mls into the vaginal mucosa and paraurethral tissue extending to behind the inferior surface of pubic bone.

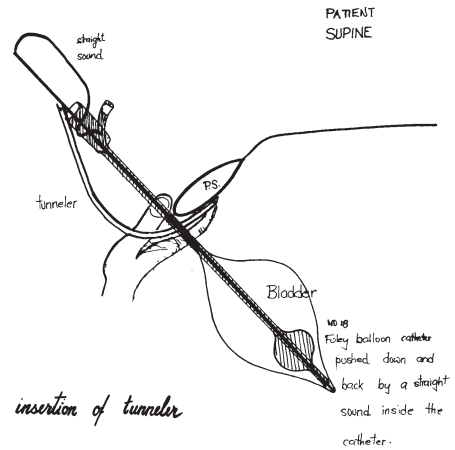

FIG 1

**Insertion of tunneller.**

The conical head is tightly controlled against the posterior surface of the pubic symphysis. The bladder is pushed down and away from the instrument.

After the bladder had been emptied, a straight introducer was inserted into a transurethraly inserted Foley catheter, FIG 1. A 1.5 cm incision was made in the mid-line just above the superior aspect of the pubic symphysis. Using a scalpel, two small vertical incisions were made laterally 1 cm inferior to the line of external urethral meatus, a special tunneller FIG 1, brought out over the superior surface of the bone into the skin incision, and a specially prepared 0.5 x 45 cm Mersilene tape inserted as described previously (1), (2), (6). The procedure was repeated on the contralateral side. Just prior to removal of the tunneller, the bladder was filled with 250-300 mls of saline, and a cystoscopy performed before proceeding further. Bilateral, paraurethral, leaf-shaped excisions of vaginal tissue, ("tucks"), 4-5 cm long by 0.5-1 cm wide were made (7), FIG 2.

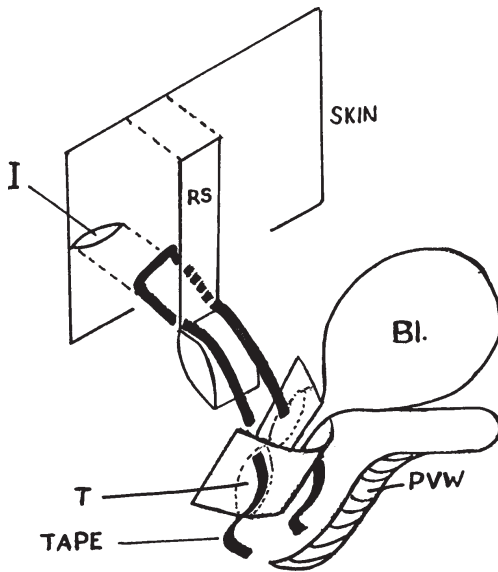

FIG 2

**The intravaginal slingplasty procedure with bilateral "tucks".**

T = "tuck"; I = incision in anterior abdominal wall; BL. = bladder; RS = rectus sheath; AVW = anterior vaginal wall; PVW = posterior vaginal wall.

The 2 limbs of the inverted "U" thus descended through the sheath, behind the symphysis, and exited into the vaginal cavity where they were trimmed and left freely protruding, FIG 2. The cut edges of vagina were approximated with interrupted No 1 Dexon, and the suprapubic wound closed. Postoperative catheterization was routinely omitted in these patients. The tape was painlessly removed per vaginam as an office procedure 6 to 8 weeks later by cutting one end level with the vaginal mucosa, and pulling on the other. In the last 10 patients, care was taken not to extend the incisions beyond the bladder neck. All failed procedures due to excessive looseness were in this group.

*Subsequent vaginal adjustment procedures.* Patients with recurrence of stress symptoms had a second minor procedure performed, either suburethral tightening ("tuck"), or I-plasty(5) p 63-67).

*I-plasty procedure.* This procedure was performed on 7 patients, and has been described elsewhere.

Essentially, it consists of a 1-1.5 cm longitudinal incision in the vagina at the region of bladder neck, separation of vagina from the bladder serosa by wide lateral and posterior dissection, and resuturing of the incision horizontally. This manoeuvre effectively increases the amount of vaginal tissue in the bladder neck region. It was also performed under local anaesthesia/ midazolam, with 300 mls of normal saline in the bladder, so that the accuracy of the adjustment procedure could be checked by coughing during the operation.

*"Tuck" procedure.* This procedure was performed on 4 patients. Under local anaesthesia/midazolam, the bladder was filled with 300 mls of normal saline. In order to estimate how much tissue to excise for return to continence, the vagina was grasped paraurethrally with Littlewood's forceps ("Pinch Test") (8), and the patient asked to cough until continence was achieved. The "tuck procedure" was then repeated as above. Sufficient vaginal tissue was excised on both sides to ensure that continence was obtained.

## RESULTS

Contact was maintained with all patients.

**Table 1**  
**Results - stress incontinence group**

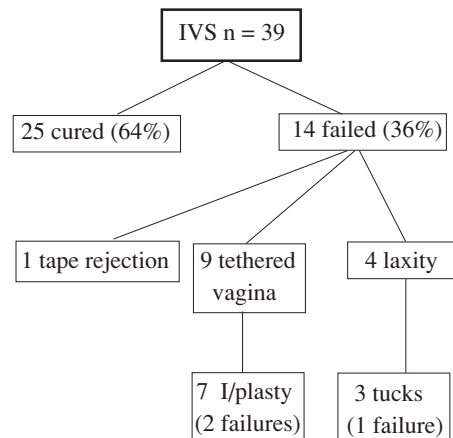

Flow chart indicating the reasons for failure and results of subsequent surgical corrections. Cure rate after adjustment = 90%.

**Stress incontinence group.** The results are summarized in Table 1. The minimal postoperative assessment period was 12 months, (mean 15 months). Total preoperative urine loss (57 patients), was 396.3 grams (mean 6.95 gm urine loss per patient), as compared to a total of 5.6 grams postoperatively in the 37 cured patients who were able to be tested (mean 0.15 gm urine loss per patient). Cough transmission ratio improved from a preoperative average of 70% to 87% postoperatively; preoperative maximal urethral pressure was 40.5 cm H<sub>2</sub>O, and this remained essentially unchanged postoperatively. Only one patient amongst those who failed was noted to have preoperative DI. There was no elevation of the bladder neck noted in any of the patients examined radiologically postoperatively.

A subsequent adjustment, Table 1, improved the total success rate to 90%, as determined by objective testing. Where both stress and urge symptoms were present, the operative cure of SI resulted in the simultaneous cure of both symptoms in the vast majority of patients. There was no new incidence of urgency in this study. Postoperative catheters were not used, and there was no postoperative urinary retention in this study.

#### **Urge incontinence group.**

All 18 urge incontinence patients were fully assessed postoperatively urodynamically, radiologically, and by pad testing. Sixteen patients were cured of their urge incontinence with the initial procedure, indicating a cure rate of almost 90% over a minimal period of 18 months. Only 4 of the 16 patients were noted to have preoperative "detrusor instability" (DI), as defined by a 15 cm H<sub>2</sub>O rise in bladder pressure on fast-fill supine cystometry; average maximal urethral pressure was 53 cm H<sub>2</sub>O; preoperative cough transmission ratio averaged 96%. All 16 cured patients were tested postoperatively. Four of these were found to have completely asymptomatic detrusor instability on urodynamic testing, and in only one patient was it present preoperatively.

#### **Flow.**

In both the urge and SI groups, the average preoperative urine flow was 28 mls/sec while postoperative flow was 26 mls/sec.

#### **Complications.**

Two patients developed suprapubic abscesses after tape removal. These were successfully treated with oral antibiotics. The bladder serosa was perforated anterolaterally by the tunneller on 2 occasions, and was recognized intraoperatively by the blood stained urine and by cystoscopic examination. The tape was withdrawn and reinserted without any complications. The catheter was left in overnight in these patients. Half of the patients reported a painless discharge which disappeared immediately the tape was removed. Some suprapubic discomfort was encountered by the 4th postoperative week in 25 % of patients, requiring early removal of the tape, in one instance, 3 1/2. weeks after insertion, without compromising the end result.

#### **Operation characteristics.**

(Slingplasty): operating time: 20-40 minutes; postoperative hospital stay: 6 to 24 hours; return to work: 2 to 10 days with no special precautions other than refraining from excess effort and intercourse; postoperative catheterization: nil.

#### **DISCUSSION**

*Restoration of function by slingplasty:* A lax vagina may not be able to achieve the "active closed position", so that the bladder neck remains "open" FIG 3, and the patient is susceptible to urine loss with stress.

*Insertion of a tape (T),* FIG 3 in the position of the pubourethral ligament (PUL) creates an artificial neoligament, against which PCM and LP can pull to close off the bladder neck.

*Stress and urge symptoms may both derive from the same anatomical defect.* Surgical cure of both stress and urge incontinence appears to confirm the main statement of the Integral Theory, (3), which states that the same anatomical defect, vaginal laxity at the bladder base, may cause both stress and urge incontinence. There was no new incidence of urge symptoms following this procedure, and no correlation was noted between preoperative detrusor instability and operative failure as suggested previously, (9). We attribute this to the bladder neck not being elevated. We attribute new incidence of bladder instability to irritation of "N" FIG 3 from below by the elevation process.



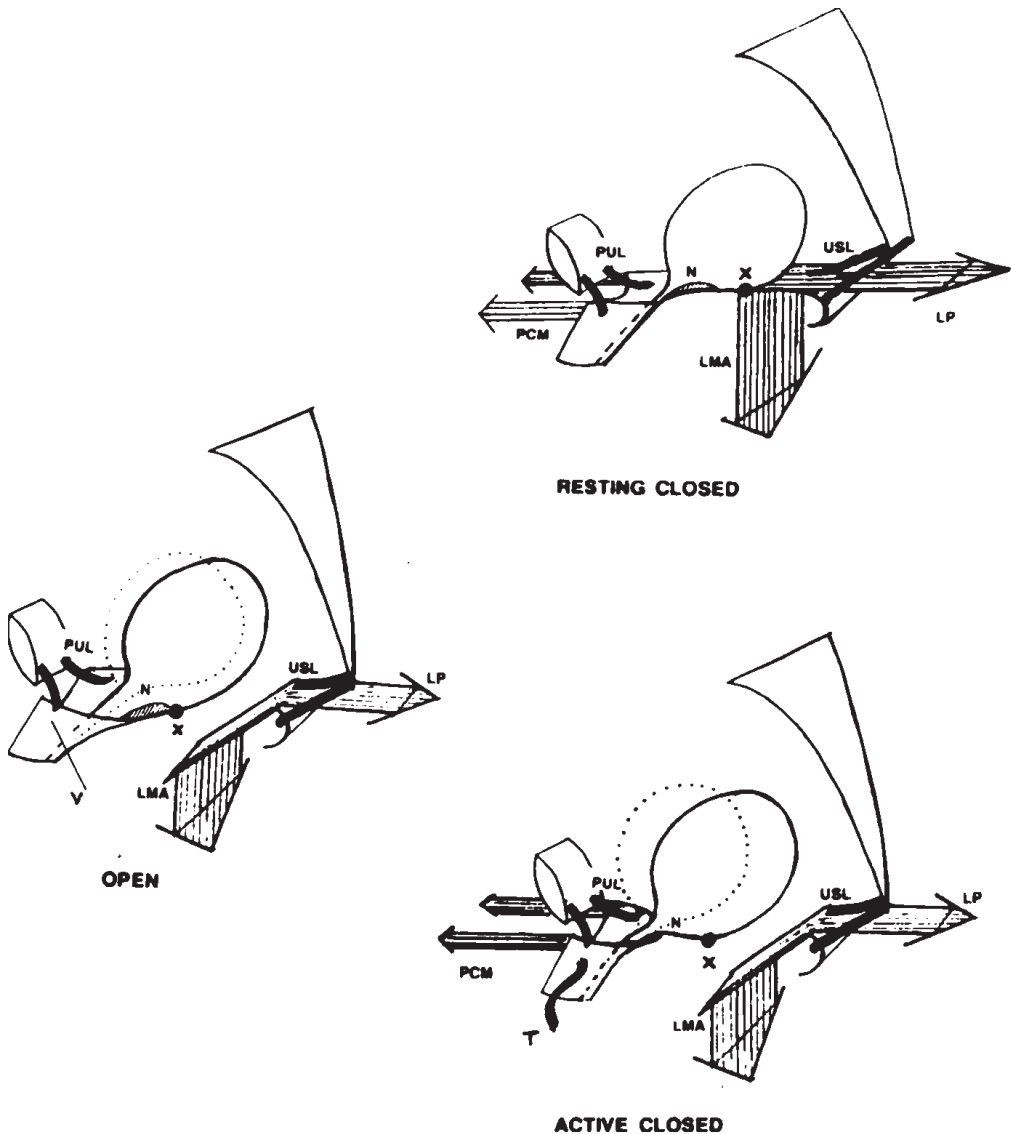

FIG 3

#### How the slingplasty restores normal function.

Reaction to "T" creates an artificial PUL fulcrum against which PCM and LP can stretch the vagina, to convert "OPEN" (incontinence) to "ACTIVE CLOSED" (continence).

Normal resting closed position: The anterior vagina is suspended superiorly by the arcus tendineus fasciae pelvis, anteriorly by the pubourethral ligament (PUL), and posteriorly by the uterosacral ligament (USL). The anterior vaginal wall (V) is attached to the bladder by the vesicovaginal ligament at (X). (N) = nerve endings at the bladder neck. (T) = Mersilene tape.

The arrow pointing to the left represents the forward contraction of the anterior portion of the pubococcygeus muscle (PCM). The arrow pointing to the right represents the backward contraction of the levator plate (LP) and the arrow pointing down represents the downward contraction of the longitudinal muscle of the anus (LMA), pulling down the levator plate. The position of the bladder in the "resting" position relative to that in the "open" or "active closed" position is indicated by broken lines.

*Aspects of tape implantation.* The operation is converted to a minimal local anaesthetic procedure by means of the “tunneller”. The design of the tunneller confers in-built safety to the procedure. The rigid tunneller ensures that there can be no wandering medially or posteriorly on insertion, towards the trigone or ureter. Perforation, on the rare occasions when it has occurred, has invariably been in the superolateral aspect of the bladder. In these instances, removal of the tape was much the same thing as removal of a suprapubic catheter. The presence of the tape facilitates drainage even when an infected haematoma forms. Our previous experimental animal studies (2), showed a far denser reaction at the vaginal end than the abdominal end with retropubic implantation of the tape. On this basis, it was considered that the potential problems of postoperative “weeping” suprapubically, and abscess formation could be solved by implanting the tape as two vertical pillars. This option is presently being pursued.

*Relevance of dysfunctional anatomy to cough transmission ratio( CTR) and urge symptoms.* We attribute the improved CTR in those patients with SI to tightening of the suburethral vagina (3). The low preoperative CTR in the SI patients is consistent with our concept (3), that SI is caused by a direct mechanical defect, a result of vaginal laxity. In the group with predominantly urge and few SI symptoms, the former are neurologically derived, being principally due to lack of inferior support for these nerve endings. Premature activation of these nerves may occur with a much more minor anatomical defect. This is reflected in a high pre-operative CTR. The aim of our surgical intervention was to restore the vaginal tension, restoring the mechanical closure mechanisms and, at the same time, supporting the nerve endings “N”, preventing premature activation of the micturition reflex.

*Effect of scarring/laxity at bladder neck.* Adequate elasticity is required in the bladder neck region of the vagina for bladder neck closure to occur, (3). The high incidence of the “Tethered Vagina Syndrome” was probably due to scarring by the “tuck” incisions.

This converts the vagina at bladder neck into a rigid connecting scar. On receiving the signal to close, LP, FIG 3, prevents PCM from closing the urethra. The bladder neck remains in the “open” position. This gives rise to the characteristic symptom of this condition, painless loss of urine prior to arrival at the toilet (5). This concept was proven by restoring elasticity in the bladder neck region of the vagina by a minor plastic operation, “I-plasty” (5). It was concluded from this, that in future, the vaginal incisions should not proceed beyond the bladder neck region in order to minimize scar formation.

#### **Conclusions.**

This study indicates how scarring in the bladder neck area of vagina may complicate female incontinence surgery. It also indicates that such scarring is potentially reversible, given that there is sufficient tissue to perform a z-plasty type of procedure (I-plasty) for restoration of tissue elasticity in this area, underlining the importance of conserving vaginal tissue when performing vaginal repairs.

#### **CORRESPONDENCE:**

P.E.PAPA PETROS  
14A/38 Ranelagh Crescent  
South Perth WA 6151  
Australia  
Fax: 61-9-474 3766

**REFERENCES**

- (1) Petros P and Ulmsten U. The Combined Intravaginal Sling and Tuck Operation: an Ambulatory Procedure for the Cure of Stress and Urge Incontinence. *Acta Obstet Gynecol Scandinavica* (1990), Supplementum No 153, 69:51-57.
- (2) Petros P, Ulmsten U and Papadimitriou J. The autogenic ligament procedure: a technique for planned formation of an artificial neo-ligament. *Acta Obstet Gynecol Scandinavica* (1990), Supplementum No 153, 69:41-49.
- (3) Petros P and Ulmsten U. An Integral Theory of Female Urinary Incontinence. *Acta Obstet Gynecol Scandinavica* (1990), Supplementum No 153, 69:7-31.
- (4) International Continence Society. Committee on Standardisation of Terminology of Lower Urinary Tract Function. Abrams P, Blaivas J, Stanton SI and Andersen JT (chairman) *Scand J Urol Nephrol*. (1988), Supplementum 114, pp 5-19.
- (5) Petros P and Ulmsten U. The Tethered Vagina Syndrome; Post-Surgical Incontinence, and I-Plasty Operation for Cure. *Acta Obstet Gynecol Scandinavica* (1990), Supplementum No 153, 69:61-65.
- (6) Petros P and Ulmsten U. Cure of urge incontinence by the combined intravaginal sling and tuck procedure. *Acta Obstet Gynecol Scandinavica* (1990), Supplement. No 153, 69:59-60.
- (7) Petros P and Ulmsten U. The Tuck Procedure, A Simplified Vaginal Repair for Treatment of female Urinary Incontinence. *Acta Obstet Gynecol Scandinavica* (1990), Supplementum No 153, 69:39-40.
- (8) Petros P and Ulmsten U. The Pinch Test for Diagnosis of Stress Urinary Incontinence. *Acta Obstet Gynecol Scandinavica* (1990), Supplementum No 153, 69:31-33.
- (9) Stanton S L. Colposuspension. *Surgery of Female Incontinence 2nd Ed.*, (1986), Eds. Stanton SL and Tanagho EA. Springer-Verlag Berlin, 95-103.
- (10) Nordin M and Frankel VH. Biomechanics of Collagenous Tissues, In *Basic Biomechanics of the Skeletal System*. Eds Frankel VH and Nordin M. Lea and Febiger Press, Phil. 1980 pp 87-110.



## FURTHER DEVELOPMENT OF THE INTRAVAGINAL SLINGPLASTY PROCEDURE - IVS III - (with midline “tuck”).

Authors:

PE PAPA PETROS\*, Dr Med Sc MRCOG FRACOG Dept of Gynaecology Royal Perth Hospital Perth, Western Australia, Dept of Obstetrics and Gynaecology Uppsala University Akademiska sjukhuset Uppsala, Sweden.

and

U Ulmsten, PD PHD Dept of Obstetrics and Gynaecology Uppsala University Akademiska sjukhuset Uppsala, Sweden

### ABSTRACT

The intravaginal slingplasty operation (IVS III), was performed under local anaesthesia on an unselected group of 39 patients, mainly with pure stress or mixed incontinence. The artificial pubourethral ligament was created by insertion of two parallel columns of tapes. The suburethral vagina was tightened by excision of a midline segment of vagina not extending beyond bladder neck. At 12 months, the primary operation cured 70% of the stress incontinence symptoms, and 85% of the urge incontinence symptoms. A minor surgical tightening of the vaginal wall at a later date improved the total cure rate to 81% for SI. Operative failure was principally attributed to “visco-elastic creep”, a subsequent loosening of vaginal tension.

Further development is required to improve the primary cure rate.

### INTRODUCTION

The intravaginal slingplasty (IVS) procedure (1) with large bilateral “tucks” failed probably because scar tissue from the bilateral “tucks” extended over bladder neck, preventing bladder neck closure, and causing the “Tethered Vagina Syndrome”, (2).

The main conclusions from the IVS study with large bilateral “tucks” was that the vaginal part of the procedure should not extend beyond bladder neck, and that the tapes would be inserted as 2 parallel columns so as to prevent abscess formation after removal of the tapes. So as to minimize the amount of scarring in the bladder neck part of vagina, it was decided to perform a single midline incision, similar to that made in a Kelly repair up to, but not extending beyond, bladder neck.

### PATIENTS MATERIAL AND METHODS

*Patients* An unselected group of 39 patients with a history of urinary incontinence were treated. Pure stress incontinence was objectively the major incontinence problem in 12 patients, pure urge incontinence symptoms in 2 patients, and painful urge symptoms in one. The remainder had mixed symptoms. Age ranged from 30 to 87 years (mean 55), parity 0 to 14 (mean 3.5), and weight from 48 to 115 kg (mean 66 kg). In the first instance, all patients had an intravaginal slingplasty with a single midline ‘tuck’ procedure performed, FIG 1. Owing to inadequate continence control, 10 patients had a further vaginal tightening performed between 1 and 3 months after the primary operation.

**Diagnostic procedures.** The test schedule was that the patients emptied their bladder first thing in the morning, took a vitamin B tablet containing 50 mg of riboflavine so as to stain the urine dark orange, drank between 1 and 2 glasses of water prior to departure, and presented for testing with a tolerably full bladder. Where possible, a further 1 or 2 glasses of water were ingested on arrival. The patient was initially tested for stress incontinence by placing a perineal pad over her vulva, and asking her to cough 10 times. Then she was asked to perform, if possible, 10 star jumps, (scissor jumps). The pad was examined at the end of each test and weighed if there was any staining. Urethrocytometry was performed essentially according to the method of Asmussen and Ulmsten (3), and included provocation with a straining, "cutting-off" and hand-washing.

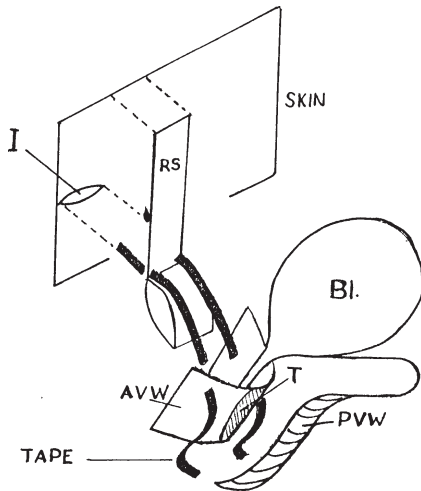

**FIG 1**  
**The intravaginal slingplasty procedure with midline "tuck".**

T = "tuck"; I = incision in anterior abdominal wall; BI. = bladder; RS = rectus sheath; AVW = anterior vaginal wall; PVW = posterior vaginal wall.

**Surgical procedure.** The insertion of the tunneller is as described previously (1). Preoperative single-dose intravenous flucloxacillin and 1 mg rectal metronidazole were used. The vaginal ends of the tapes were trimmed to a protruding length of 1.5 to 2 cm, and fastened to the vagina by a side-to-side suture which also transfixed the lower end of the tape.

**Midline "tuck".** The bladder was filled with 300 ml of normal saline. A midline incision was made, making sure that it did not extend beyond bladder neck. The flaps were dissected off the urethra. In order to estimate how much tissue to excise for return to continence, the two flaps of vagina were grasped paraurethraly with Littlewood's forceps, and the patient asked to cough until continence was achieved. Sufficient vaginal tissue was excised on both sides at the same time checking directly that continence was obtained. Postoperative catheterization was routinely omitted in these patients. The tape was painlessly removed per vaginam as an office procedure 6 to 8 weeks later simply by pulling on the protruding vaginal ends.

**Criteria for cure.** The patients were assessed using a structured semi-quantitative questionnaire by an independent external observer. They were also asked to assess what percentage cure had been achieved.

## RESULTS

Contact was maintained with all but one patient. The mean postoperative observation time was 12 months, calculated after the last procedure if a postoperative adjustment was made.

At completion of the primary operation, almost all of the patients were completely cured of SI. As the operations were almost entirely performed under local anaesthesia, we were able to excise the precise amount of vaginal tissue necessary to achieve continence. However, at 12 months, only 26 of 37 patients with symptoms of SI (70%) and 23 of 27 of patients with symptoms of urge incontinence (85%) remained cured. Recurrence of SI, when it occurred, invariably did so within 2 months in this group of patients. One of 2 patients with pure urge incontinence, and 1 patient with painful urge symptoms were cured. A further suburethral vaginal tightening was made in 11 of the failed SI patients. This improved the cure rate for SI to 81%. A further 8% reported an improvement. Stress and urge symptoms, where present, were simultaneously cured in the vast majority of patients. There was no new incidence of urgency. Postoperative catheters were not used, and there was no postoperative urinary retention.

*Complications.* There were no postoperative infected retropubic haematomas. The bladder was perforated by the tunneller on one occasion. This was recognized intraoperatively by the blood stained urine and by cystoscopic examination. The tape was withdrawn and reinserted without any complications. The catheter was left in overnight in this patient. Half of the patients reported a painless vaginal discharge which disappeared immediately the tape was removed.

*Operation characteristics (Slingplasty):* operating time: 20-40 minutes; postoperative hospital stay: 6 to 24 hours; return to work: 2 to 10 days with no special precautions other than refraining from intercourse; postoperative catheterization: nil.

## DISCUSSION

The simultaneous cure of stress and urge incontinence again confirmed the main statement of the Integral Theory (3), which states that the same anatomical defect, vaginal laxity is mainly responsible for both symptoms. There was no bladder neck elevation in this operation, indicating that the important cure factor was creation of an artificial pubourethral ligament, and adequate tensioning of the suburethral vagina. Implantation as 2 parallel columns appears to have improved the problem of postoperative suprapubic "weeping" and eliminated the small but bothersome postoperative infected haematomas caused by pulling on the inverted "U" configuration of the tape during removal.

*Recurrence of symptoms.* The exact amount of vagina was excised intraoperatively, restoring continence with a full bladder during coughing. We attribute the postoperative recurrence of suburethral laxity and stress incontinence to the process of "visco-elastic creep" (5), i.e. the force of muscle contraction rearranges the ground substance of the vaginal connective tissue, in effect averaging out the force acting over the whole vagina, resulting in a relative loosening of the suburethral vagina, re-creating a mechanical closure defect.

## Conclusions.

There were no cases of "tethered vagina syndrome", indicating the importance of leaving the bladder neck part of vagina free of scar tissue. However, we incurred the problem of postoperative "visco-elastic creep". Excision of additional vaginal tissue at the time of the initial operation is not an option for this procedure, as it carries a significant risk of causing the "tethered vagina syndrome. Therefore, in order to improve the primary cure rate, we need to be able to tighten the suburethral vagina in a way which prevents "visco-elastic creep", without compromising the elasticity in the bladder neck area.

**Acknowledgement** We would like to thank Dr Donald Clarke FRACOG for his assistance in the assessment process.

## CORRESPONDENCE:

P.E.PAPA PETROS  
14A/38 Ranelagh Crescent  
South Perth WA 6151  
Australia  
Fax: 61-9-474 3766

## REFERENCES

- (1) Petros P and Ulmsten U. This issue.
- (2) Petros P and Ulmsten U. The Tethered Vagina Syndrome; Post-Surgical Incontinence, and I-Plasty Operation for Cure. Acta Obstet Gynecol Scandinavica. Supplementum No 153, (1990), 69:61-65.
- (3) Ulmsten U, Asmussen M, and Lindstrom K. A new technique for simultaneous uethrocystometry and measurements of the urethral pressure profile. Urol Int. (1977), 32:88-92.
- (4) Petros P and Ulmsten U. An Integral Theory of Female Urinary Incontinence. Acta Obstet Gynecol Scandinavica. Supplementum No 153, (1990), 69:7-31.
- (5) Nordin M and Frankel VH. Biomechanics of Collagenous Tissues, In Basic Biomechanics of the Skeletal System. Eds Frankel VH and Nordin M. Lea and Febiger Press, Phil. 1980 pp87-110.





# THE FURTHER DEVELOPMENT OF THE INTRAVAGINAL SLINGPLASTY PROCEDURE: IVS IV - (with “double-breasted” unattached vaginal flap repair and “free” vaginal tapes).

Authors:

PE PAPA PETROS\*, Dr Med Sc MRCOG FRACOG Dept of Gynaecology Royal Perth Hospital Perth, Western Australia, Dept of Obstetrics and Gynaecology Uppsala University Akademiska sjukhuset Uppsala, Sweden.

and

U Ulmsten, MDPHD Dept of Obstetrics and Gynaecology Uppsala University Akademiska sjukhuset Uppsala, Sweden.

## ABSTRACT

The Intravaginal Slingplasty with “double-breasted” vaginal flap repair and free vaginal tapes as performed in 40 unselected patients with primarily mixed or pure stress incontinence solved the problems of “visco-elastic creep” and of the “tethered vagina syndrome”, but had a primary cure rate of only 72%, due to the tearing out of either the internal or external flaps. Subsequent adjustment under local anaesthesia improved the cure rate to 92%. Further development of the vaginal part of this technique is required.

## INTRODUCTION

The problem as identified in IVS 111 was how to prevent “visco-elastic creep”, without creating a scar at the bladder neck, therefore risking occurrence of the “tethered vagina syndrome”.

The anatomical basis for the “double-breasted” vaginal flap repair: the urethra is free of attachments in its upper 1/3. In the lower 2/3 of urethra, however, the vagina is densely adherent (1). It is known that the vagina is elastic (2). We hypothesized that “visco-elastic creep” was essentially an equalization of tissue tension created by contraction of the pelvic floor, and that a “double-breasted” vaginal flap repair, FIG 1, sited at the lower 2/3 of urethra would ensure that there was no movement due to “visco-elastic creep” in the longitudinal axis because of the fibrous connection between the layers, as fibrous tissue is not elastic (3). Theoretically, stretching in the transverse axis should be unhindered. We considered that there would be no problems with inclusion cysts. The vagina has no glands, and there is no keratinization (1). During a 5 year personal experience in over 100 cases of the Raz “island patch” technique whereby a square patch of vaginal epithelium is buried below the vagina, no case of inclusion cyst formation (4) was found.

## PATIENTS, MATERIAL AND METHODS

*Patients.* An unselected group of 40 patients with a history of urinary incontinence was treated. Pure stress incontinence was objectively the major incontinence problem in 13 patients, pure urge incontinence symptoms in 4 patients, and mixed symptoms in 23 patients. Age ranged from 17 to 79 years (mean 52), parity 0-8 (mean 2.4) and weight from 45-102 Kg (mean 62 kg). The patients were objectively assessed as previously described (IVS III).

*Surgical procedure.* A specially prepared 0.4 x 45 cm Teflon tape was used. The essential parts of the tape insertion were carried out as previously described (IVS III). The vaginal ends of the tape were sutured to the vaginal mucosa, and trimmed, leaving 1-2 cm of tape protruding into the vaginal cavity. The inverted “U” was cut in its midpoint just above the level of the sheath, so that the tape now descended as two parallel lines behind the pubic symphysis.

*The vaginal part of the procedure* (FIG 1). The Foley catheter was re-inserted. Using a scalpel, flaps were created, FIG 1 A&B, stopping 0.5-1.5 cm short of bladder neck (avg. 1.0 cm), depending on whether the urethra is very long or very short. The superficial epithelial surface of the underlying inner flap was

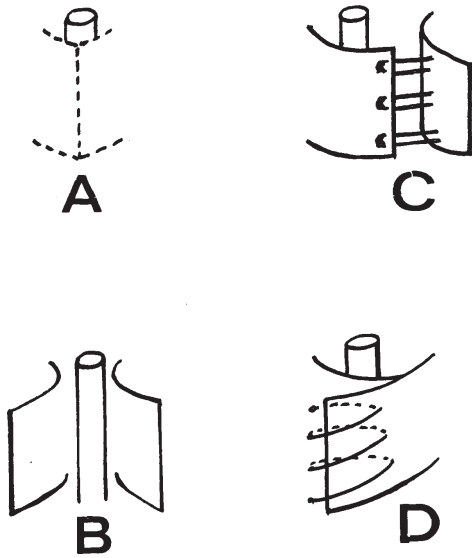

FIG 1

**Double-breasted vaginal flap repair.**

A = vertical incision in vagina; B = creation of flaps; C = fixation of inner flap; D = fixation of outer flap.

diathermied, and the flap secured to the inner aspect of the external flap using Sturmdorf-type sutures, FIG 1C. The external flap was then brought over and sutured to the outer surface of the inner flap using continuous 2-0 Vicryl sutures, FIG 1D. Postoperative catheterization was routinely omitted. The tape was removed per vaginam as an office procedure 6 to 8 weeks later by pulling on the vaginal ends.

**RESULTS** (Table 1)

Contact was maintained with all patients. Primary cure rate was 72%, (82% if part cure included). Assessment was by questionnaire and self-assessment of the patient, with overseeing of this by an external observer experienced in incontinence surgery.

TABLE 1

	pre-op	cured	cure after adjustment
UI only	4	3	3
SI only	13	6	12
Mixed SI / UI	23	19	22
TOTAL	40	28	37 %
CURE		(72%)	(92.5%)

The external flap tore out in 8 patients. Five of these were cured of their stress symptoms, but urge symptoms remained. A later re-attachment of the torn-out flap in 4 of these patients cured the urge symptoms. In 6 patients, the incontinence appeared to worsen, and the patients complained of "leaking all the time". The external flap appeared to be intact in these patients. Re-exploration by incision of the vagina in the midline, revealed that the urethra had become dilated and incompetent. Plication of the urethra, and re-tightening of the suburethral vagina restored continence dramatically in 4 of the 6 patients. The other two were cured of the symptom of "leaking all the time", but remained partly incontinent. There was no new incidence of urgency in this study. Postoperative catheters were not used, and there was no postoperative urinary retention. Almost all patients reported a non-bothersome postoperative thick yellow vaginal discharge, which cleared on removal of the tapes.

**DISCUSSION**

The results indicate that the double-breasting process appears to have achieved its primary objectives, to prevent postoperative "visco-elastic creep". We identify another problem, the potential tearing-out of the restraining sutures for the flaps.

Failure occurred primarily for mechanical reasons, tearing out either of the internal or external flaps. We hypothesized that a major reason for the external flap tearing out was that the unfixed edge of the external flap became devascularized, pre-disposing to the sutures tearing through it. Also, the flaps were brought across under tension, predisposing to retraction. With regard to the inner flap, we consider that fixation by Sturmdorf sutures is a flawed technique, as it appears to predispose to retraction, fibrosis and urethral incompetence. Cure of urge symptoms after the loose flap was re-attached indicates the supportive function for the hypothesized bladder nerve endings at bladder base by vagina.

**Conclusions.**

The technique of fixation of both inner and outer flaps needed to be revised so that the fixation technique automatically predisposes to a) minimal tension on the flaps; b) adequate vascularization of the outer flap; c) the forces acting on the inner flap push it towards the urethra, not away from it.

**CORRESPONDENCE:**

P.E.PAPA PETROS

14A/38 Ranelagh Crescent

South Perth WA 6151

Australia

Fax: 61-9-474 3766

**REFERENCES**

- (1) Krantz K. The anatomy and physiology of the vulva and vagina and the anatomy of the urethra and bladder. Scientific Foundation of Obstetrics & Gynaec. (1977), 2nd Ed, (Eds) Philipp EE, Barnes J, Newton M, William H Philadel. 65-78.
- (2) Yamada H. Mechanical properties of urogenital organs and tissues in Strength of Biological Materials, (1970), Williams & Wilkins Co, Baltimore. Ed Evans FG. 205-218.
- (3) Peacock EE. Structure, synthesis and interaction of fibrous protein and matrix. Wound Repair. (1984), 3rd Edition, Publishers WB Saunders Co, Philadelphia. 56-101
- (4) McGregor B. Personal communication (1990)



## FURTHER DEVELOPMENT OF THE INTRAVAGINAL SLINGPLASTY PROCEDURE: IVS V - (with “double-breasted” unattached vaginal flap repair and permanent sling).

Authors:

PE PAPA PETROS, Dr Med Sc MRCOG FRACOG Dept of Gynaecology Royal Perth Hospital Perth, Western Australia, Dept of Obstetrics and Gynaecology Uppsala University Akademiska sjukhuset Uppsala, Sweden and

U Ulmsten\*, MD PHD Dept of Obstetrics and Gynaecology Uppsala University Akademiska sjukhuset Uppsala, Sweden

### ABSTRACT

Stress incontinence was cured under local anaesthesia in an unselected group of 47 patients with a history of either pure stress or mixed urinary incontinence by insertion of a permanent sling and by double-layer tightening of suburethral vagina. The primary cure rate was found to be 78% for stress incontinence. It was found that the external flap tore out in a large number of patients. When compared to the “free tapes” version (IVS IV), the primary cure rate with the permanent tape version was 10% superior. This indicates that the tape may provide an extra protective measure in cases where the vaginal part of the procedure fails, at least for stress incontinence. There were, however, some incidences of post-operative urinary retention.

### INTRODUCTION

Even though the two elements necessary for successful surgery, re-creation of the posterior pubourethral ligaments, and adequate tightening of the suburethral vagina were ratified with each version of the IVS procedure to date, the proper restoration of function of the vaginal part of the procedure has remained a continuing problem. Another option considered was to create a more efficient bladder neck closure mechanism (1) by insertion of a permanent sling, a long Scandinavian tradition, but with several important differences: there was to be no elevation; the sling was not to be fixed superiorly; it was to be located at the mid-urethra; there was to be a concomitant “double-breasted” flap repair of vagina. It was felt important to continue with the tightening of vagina principally to provide support for the presumed nerve endings at bladder base, so as to prevent premature activation of the micturition reflex.

### PATIENTS MATERIALS AND METHODS

*Patients.* An unselected group of 47 patients with a history of urinary incontinence were treated. Age ranged from 43 to 76 years (mean 52), parity 1-6

(mean 2.4), and weight from 47-96 Kg (mean 64 kg). Pure stress incontinence was objectively diagnosed in 35 patients, while 12 patients also had urge incontinence symptoms. All patients were fully tested urodynamically as described in IVS III. In 2 patients, Goretex was used, in 4 patients 4 mm Teflon was inserted. The remainder had 5 mm Mersilene inserted.

*Surgical procedure* This was performed entirely under local anaesthesia. Teflon, Mersilene or Goretex were used. Flaps were created and the operation performed as previously described (IVS IV), up to the point where the tunneller was inserted for the 2nd time on the contralateral side. Having checked cystoscopically that there was no tape in the bladder, the outer sheath of the tunneller was removed, leaving the insert in situ. The free end of tape already in the vagina was then threaded into the eye of the needle, and the insert was pulled upwards. Care was taken to lie the tape flat across the mid-point of urethra, and to ensure that there was no tension at all suburethrally. The patient was asked to cough so as to test for continence, prior to proceeding to the vaginal part of the procedure. Finally the flaps were fixed with Sturmendorf sutures as in IVS IV. A No 8 Hegar dilator

was inserted into urethra, and pressed gently downwards so as to ensure that the sling was not interfering with the urethra. Postoperative catheterization was routinely omitted in these patients.

## RESULTS

There were no intraoperative complications. Postoperative contact was maintained with all patients. Assessment was made by a third person skilled in incontinence surgery, using a standard questionnaire form, and by specific interrogation at a mean time of 12 months (range 6-18 months). Each patient was asked to assess her cure rate, whether she was completely cured or improved to >50% or >75%, or whether the operation had failed. All patients were tested with cough provocations with a comfortably filled bladder in supine and standing positions.

The primary operation completely cured 37 patients (78%) with symptoms of SI, while 6 patients (13%) reported more than 75% improvement, i.e. the patient leaked urine only occasionally at severe cold episodes etc. These latter 6 patients considered themselves as restored to a "complete normal life". Of the 12 patients with also symptoms of urge incontinence, 4 were entirely cured. The remaining 8 patients still reported urgency symptoms, but only two had incontinence. There was no new incidence of urgency in this study. In 2 patients, a sinus formed at 2 and 3 months postoperatively, requiring removal of the sling. Both patients had Goretex sling. Continence was maintained after sling removal. Postoperative catheters were not routinely used. There was postoperative urinary retention in 4 patients. Three were able to urinate within 24 hours. One patient required catheterization for a week. In four SI patients (9%) the operation failed. In two this was obviously due to failure of the vaginal plasty (flaps tearing out) as seen already after 4-6 weeks. In the remaining two failures no obvious reason for the failure could be shown. Thirty-five patients were urodynamically examined before and after the surgery. There were no significant changes in the urethral pressure profile. In patients cured the urethral closure pressure was positive in all but two. No de novo detrusor instability was recorded postoperatively.

## DISCUSSION

*Advantages of the permanent tape.* When compared to the results of the "free tapes version" (IVS IV), the results indicate that the use of a permanent sling gives an extra dimension of strength to the procedure, at least as concerns the surgical cure of stress incontinence. Leaving the tape in creates a fairly strong inferior fulcrum for the bladder neck closure mechanism and providing a back-up mechanism for continence, if the internal layer of the "double-breasted" tuck loosens. Such a firm inferior fulcrum may not be possible in patients with "free tapes". They rely on the actual vaginal tissue to be sufficiently strong to provide this inferior fulcrum. The failure to cure urge symptoms comprehensively we attribute to the tearing out of the outer flap, preventing the vagina from being tensioned sufficiently to prevent the nerve endings at the bladder neck from firing off. In these situations, further postoperative tightening of the vagina is necessary to cure any residual urgency. Clearly, such tearing out indicates that the methodology for fixation of the flap was faulty. The edge of the outer part of the flap cannot undergo healing by primary intention. Instead, it relies on the process of healing by secondary intention, the inner surface of the outer flap to the outer burnt part of the inner flap. Whereas theoretically, the arrangement of sutures was to allow sliding of the outer flap if the apposition was too tight, this did not necessarily happen. The presumed devascularization of the edge of the outer flap probably allowed the sutures to tear through the now devitalized edge of the outer flap. On inspection this appeared to be the case.

## Conclusion.

This technique seems to give overall acceptable cure of >90% in patients with SI and combined SI and UI. Since the patients have been followed for only one year the definitive cure rate has still to be awaited for another 2-3 years. It seems, however, justified to conclude that the described procedure should be considered a promising alternative for surgical cure of female urinary incontinence. The results also imply that then free tapes version could be improved by "crossing over" the tapes to create a firm fibrous suburethral band to facilitate the "kinking" of the bladder neck closure mechanism.

**CORRESPONDENCE:**

U. Ulmsten  
Dept of Obstetrics and Gynaecology  
Uppsala University  
Akademiska sjukhuset  
Uppsala, Sweden  
Fax: 46 18 55 97 75

**REFERENCE**

- (1) Petros PE & Ulmsten U. An Integral Theory of Female Urinary Incontinence. Acta Obstet. Gynecol.Scandinavica. (1990), Supplementum No 153, 69:7-31.





## THE INTRAVAGINAL SLINGPLASTY PROCEDURE: IVS VI - further development of the “double-breasted” vaginal flap repair - attached flap.

Authors:

PE PAPA PETROS\*, Dr Med Sc MRCOG FRACOG Dept of Gynaecology Royal Perth Hospital Perth, Western Australi, Dept of Obstetrics and Gynaecology Uppsala University Akademiska sjukhuset Uppsala, Sweden and

U Ulmsten, MDPHD Dept of Obstetrics and Gynaecology Uppsala University Akademiska sjukhuset Uppsala, Sweden

### ABSTRACT

The principal aim of this study was to create a more efficient method of suturing the vaginal flaps using the “double-breasted” flap repair technique, in order to prevent tearing out, a principal reason for postoperative failure. The preliminary results in 21 patients using both “free tapes” and permanent sling methods indicate that the new technique appears give a markedly improved primary cure rate.

### INTRODUCTION

The “double-breasted” flap repair technique as used in the Intravaginal Slingplasty IV and V appeared to have solved previous problems of “visco-elastic creep” and of the “tethered vagina syndrome” as causes of postoperative failure. However, the new method of creating the “double-breasted” flap repair was clearly faulty. Analysis of the previous methodology with regard to the biomechanical principles as described in Parts II & III, indicated that mechanical failure could be solved by ensuring that the flaps were not pulled across under tension, that devascularization of the external edge of the flap could theoretically be prevented by creating a cut edge in the internal flap, FIG 1, ensure primary revascularization, and tissue healing by primary intention. We regard urethral dilatation by fibrous retraction of the inner flap as a major potential problem. We proposed plication of the outer surface of urethra where it was lax, a more precise method of fixing the inner flap to the lateral side of urethra, and the insertion of tension sutures on the outer surface of the inner flap, so that they automatically compressed the inner flap towards the urethra on effort, FIGS 1-3. These tension sutures should also help protect the suture line of the external flap FIGS 1&2.

### MATERIALS AND METHODS

*Patients.* An unselected group of 21 patients with a history of urinary incontinence was treated. The patients were pre-operatively assessed as previously described (IVS III). Teflon tapes were inserted as before and left free in the vagina in 12 patients, and as a permanent sling in 9 patients. Pure stress incontinence was objectively the major incontinence problem in 4 patients, and mixed symptoms in the remainder. Age ranged from 39 to 76 years (mean 51), parity 1-5 (mean 3), and weight from 48-82 Kg (mean 63 kg).

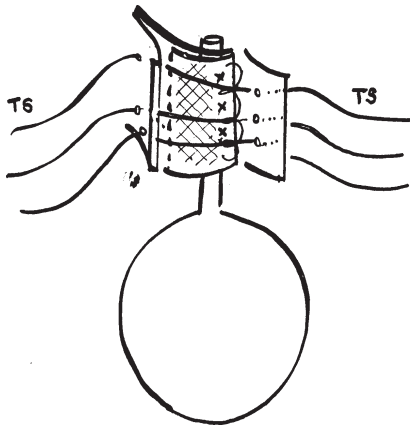

FIG 1

**Fixation of inner flap**

The inner flap has been sutured paraurethraly on the left side with interrupted and continuous sutures. The broken lines on the patient's right indicate the position of the vertical incision which has been made on the epithelial surface of the inner flap. TS = tension sutures.

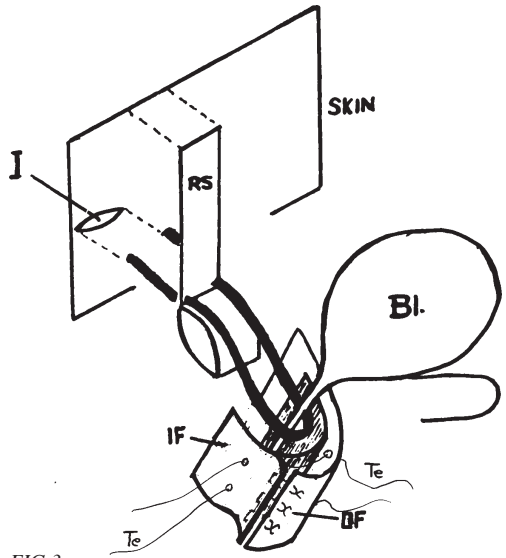
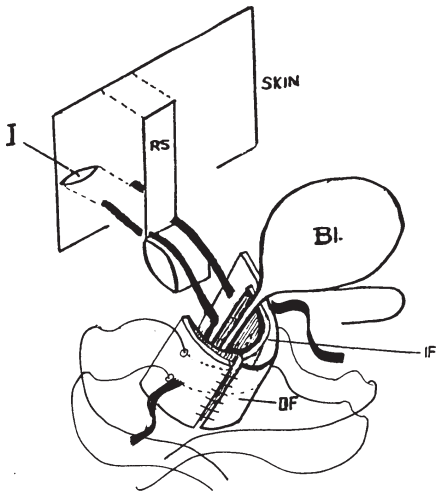

FIG 3

**Fixation of the outer flap - permanent sling.**

This is a schematic representation of the completed operation. IF = inner flap; OF = outer flap; BI = bladder; RS = rectus sheath; Te = tension sutures; I = 1.5 cm skin incision



IVS - removable tapes

FIG 2

**Fixation of the outer flap - "free tapes".**

This is a schematic representation of the completed operation. IF = inner flap; OF = outer flap; BI = bladder; RS = rectus sheath; I = 1.5 cm skin incision.

Tape was inserted and flaps prepared as previously described (IVS IV). The 1st flap was gently pulled across the midline and sutured to the paraurethral tissue just lateral to the urethra using 2 to 3 interrupted 000 Vicryl sutures, and then with a second continuous suture. The superficial epithelial surface of that part of the inner flap to be buried was diathermied. A vertical incision was made on the epithelial surface of the inner flap down to the muscularis layer of the vagina, FIG 1, so that when the 2nd flap was gently brought across the midline, it could be sutured to the vertical cut surface of the inner flap, without any significant tension. Two or three 00 Vicryl "tension" sutures, FIG 1, were inserted, taking care that the suture passed outside the inner flap, FIG 1. The external flap was then sutured to the incised epithelium using 000 horizontal mattress sutures, FIGS 2&3, and the 'tension' sutures loosely tied over a pair of suture scissors, leaving a 1cc gap between sutures and vaginal epithelium.

Postoperative catheterization was routinely omitted in all patients. The tape was removed per vaginam as an office procedure 6 to 8 weeks later by pulling on the vaginal ends.

## RESULTS (Table 1)

### At 3 months

Contact was maintained with all patients. Assessment was by questionnaire and self-assessment of the patient, with overseeing of this by an external observer experienced in incontinence surgery. The external flap tore out in 3 patients postoperatively, a consequence, we believe, of postoperative coughing or vomiting attacks. Despite this, at 12 weeks, 19 patients reported more than 90% primary cure of their SI symptoms. Of the 3 who tore the external flap, one was cured of SI, but complained of urge symptoms. These disappeared immediately the flap was re-approximated 12 weeks later. The 2nd was more than 50% improved. The 3rd was a total failure. Four patients reported continuing urgency postoperatively, but these symptoms settled within 2 weeks. Three patients complained of increasing suprapubic pain postoperatively, usually beginning on the 3rd postoperative day. This continued until the lower tension sutures, FIGS 1&2 burst or were cut. One patient with a permanent sling could not urinate postoperatively, and required catheterization for 24 hours.

### At 9 months

Of the 19 cured patients, 18 were assessed after a further 6 months. Only one reported partial recurrence of symptoms, and this appeared to be due to suburethral vaginal laxity.

## DISCUSSION

The problem of the flaps tearing-out of sutures appears to have been mostly solved using this technique. The results, albeit preliminary, emphasize that attention must be paid to the biomechanical aspects of connective tissue, i.e. the structural strength of vagina, its elasticity, the muscular forces to which it is subjected, and, above all, how the surgical technique used may either protect or predisposes to rupture of the suture line. With regard to the latter, we stress that the flaps must not be pulled over too tightly. The improvement in postoperative urge symptoms we attribute to subsequent "visco-elastic creep" lessening the upward tension we presume caused these symptoms in the first place.

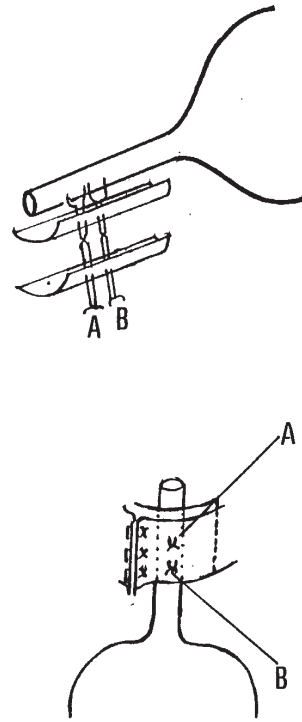
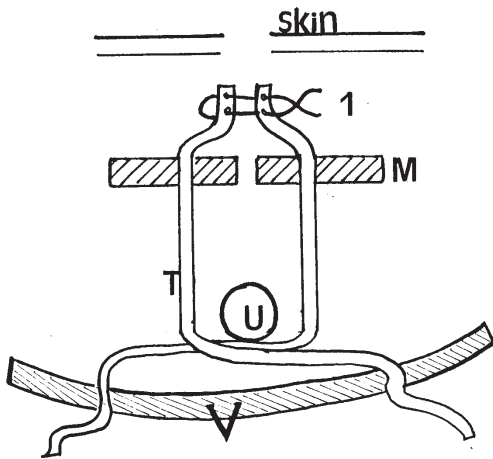

FIG4

### Improved Periurethral anchoring of vaginal flaps

After the flaps have been opened out, 2 anchoring sutures, A & B are inserted deep into the paraurethral tissues, and brought out through both flaps as indicated, fixing each flap in turn with the same sutures. Care must be taken not to tie the sutures too tightly. If a urethral plication is made, then the same sutures can be brought through the flaps. This manoeuvre also assists fixing of the flaps, which still has to be performed as indicated in FIGS 1,2 &3.



**FIG5**  
**“Cross-over free tapes”**

The tapes are crossed directly below the urethra, taking care that they are situated well forward of the mid-urethra. They are tied superiorly ONLY with No1 Vicryl, and left entirely free at the vaginal level. This ensures that there can be no injury to the urethra. T = tape; U = urethra; V = vagina; M = rectus muscle.

### Conclusion

Use of tension sutures may sometimes cause pain, especially if tied too tightly. *Analysis of this surgical variation with regard to the normal anatomy (1)* indicates that attachment paraurethrally or to the urethra itself would better re-create the dense fibrous tissue attachment of urethra to vagina. Attachment in the manner of FIG 4 is already being performed. Preliminary results (unpublished data) are most optimistic, indicating that the vagina is firmly attached, without post-operative pain. However, we have found that there is a much greater possibility of post-operative urinary retention, especially if the attaching sutures proceed beyond mid-urethra. Experience using the permanent sling suggest that a “cross-over” method of tape insertion in the “free tapes” version of this procedure, FIG5, would give most of the advantages of a permanent sling. Preliminary results are optimistic.

### Postscript

As a general comment, many patients whom we had regarded as being total operative failures with the IVS IV, V and VI versions subsequently reported a significant improvement in their stress incontinence symptoms (unpublished data). We attribute this to the tightening which would result from scar tissue contraction around the double flap repair, a result of inter and intramolecular cross-bonding.

### CORRESPONDENCE:

P.E.PAPA PETROS  
 14A/38 Ranelagh Crescent  
 South Perth WA 6151  
 Australia  
 Fax: 61-9-474 3766

### ACKNOWLEDGEMENT:

To Dr Harald Bratt and Proffesseur Per Johnson for discussions leading to improved technique as demonstrated in Figures 4 and 5 respectively.

### REFERENCE

Krantz KE. Anatomy of the urethra and anterior vaginal wall. *American J. Obstet Gynecol.* (1950), 62:374-386.

# THE FREE GRAFT PROCEDURE FOR CURE OF THE TETHERED VAGINA SYNDROME

Authors:

PE PAPA PETROS\* Dr Med Sc MRCOG FRACOG Dept of Gynaecology Royal Perth Hospital Perth, Western Australia, Dept of Obstetrics and Gynaecology Uppsala University Akademiska sjukhuset Uppsala, Sweden and

U Ulmsten, MD PHD Dept of Obstetrics and Gynaecology Uppsala University Akademiska sjukhuset Uppsala, Sweden

## ABSTRACT

Symptoms of stress and urge incontinence in 12/16 patients with the “tethered vagina syndrome” were substantially cured by insertion of a free graft in the vagina in the area of bladder neck. The operation works by restoring elasticity in the vagina below bladder neck, thus allowing the bladder neck and urethral closure mechanisms to operate independently.

## INTRODUCTION

Urinary incontinence due to decreased elasticity in the vagina below bladder neck, (“tethered vagina syndrome”), has been previously described as an important cause of postsurgical incontinence (1). Surgical cure of such patients has been previously reported using the “I-plasty” operation. *In biomechanical terms, however, this operation cannot permanently restore elasticity in the bladder neck area of the vagina if there is a net deficit of tissue, due to previous vaginal excision, or if the elasticity in this area has been compromised by excessive elevation.* Initially the graft operation was performed in those patients who had failed I-plasty procedure (1), a technique which imports healthy vaginal tissue to the bladder neck area. Later it was performed as a primary operation in patients diagnosed as having the “tethered vagina syndrome”.

## PATIENTS, MATERIAL AND METHODS

A total of 16 patients were diagnosed as having the tethered vagina syndrome. Age ranged from 35 to 91 years, mean age 68 years. Parity ranged from 1-6, mean 3.

*Pre and post operative assesment .*

All patients were fully assesed as previously described IVS II-VI This issue.

*Operation.* A full thickness 4 cms long horizontal

incision was made exactly in the transverse crease of the bladder neck area of the vagina, FIG 1. This was opened longitudinally with a pair of long handled scissors. Scar tissue below the vagina was excised. Haemostasis was ensured by diathermy. A 4 x 3 cm full thickness vaginal graft was taken from the posterior vaginal wall in the analogous position to the transverse incision, or as skin from the anterior abdominal wall or buttock. The vagina from whence it was taken was sutured in the anteroposterior direction to ensure that there was no narrowing at the site. Where relevant, the graft was trimmed of all underlying fat and sutured into the bladder wall initially with four quilted sutures and peripheral sutures 3 mm apart interrupted (3/0 Vicryl). No vaginal packs were applied and a catheter was put into the patient overnight only. Generally the patient was allowed to go home on the next day and instructed to rest at least for a week to allow the graft to heal.

## RESULTS

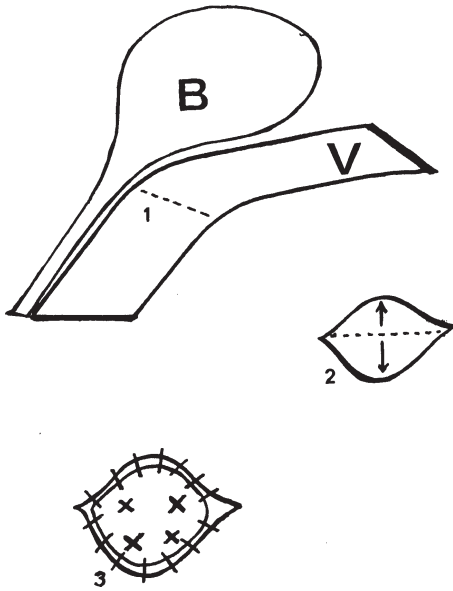

**FIG 1**  
Free graft repair. The numbers 1, 2 & 3 denote the successive stages of the operative procedure. X = quilting sutures to the bladder tissue; B = bladder; V = vagina.

Twelve patients gave a history of having undergone a previous bladder neck elevation procedure, and 4 patients had undergone at least one previous vaginal repair. In all, more than half of the patients had undergone a previous failed I-plasty. Mean postoperative follow up was 9.2 months. Range 3-13 months. *Symptoms.* All patients had symptoms of frequency, urgency and nocturia. Urge incontinence was present in 15 out of the 16 patients. All patients wet frequently prior to arrival at the toilet, and in 13/16 patients, this symptom was invariable. Stress incontinence with coughing was present in only 7 out of 16 patients. Another 7 out of the 16 patients complained of leakage either on bending over or during walking, but not on coughing, i.e. paradoxical leakage (so named because of leakage at a lower pressure than on coughing). Maximal urethral pressure ranged from 8 to 52 cms mean 20 cms.

*Radiological Diagnosis.* In patients with a net deficit of elastic tissue in the interior vaginal wall, there may be very little movement of the bladder neck on straining (cf FIGs 11a, 11b Part I)

*Surgical results.* Eleven patients reported a cure rate of

all symptoms in excess of 90%. One patient reported cure of her urge incontinence but continuation of her frequency. Four out of 16 patients reported a rejection of the graft. This generally occurred within the first week and in all cases a dark brown chocolate discharge was noted. There did not appear to be any greater rejection of skin as opposed to vaginal grafts. Where the operation was successful, symptoms took 2 to 4 weeks to improve. Thereupon, further improvement was noted over the next four months. One patient who was entirely cured reported return of incontinence symptoms 6 months postoperatively, though they were different to the original symptoms. Investigation demonstrated that the suburethral vagina had become very loose, we assume from too large a graft. A double flap repair performed under day surgery conditions with local anaesthesia completely cured this patient. All 4 patients who reported rejection of their flaps also reported worsening of their symptoms over the ensuing 6 months.

*Skin Grafts:* In 5 patients there was a net deficit of tissue in the posterior vaginal wall, so that there was insufficient tissue available to perform a graft. In these patients, skin was taken from the buttock or abdomen, trimmed and sutured accordingly.

*Cough transmission ratio.* This was more than 90% in 13 patients (in 9 patients it was more than 100%). In 2 patients however, the cough transmission ratio was in the range of 60-65%, and in one patient, 85%.

## DISCUSSION

*Modus operandi of the operation.* The graft restored the elasticity at ZCE, (FIG 3 theory section), thereby permitting the urethral and bladder neck mechanisms to function separately. Over-correction was noted in one patient, i.e. the suburethral tissues were rendered excessively loose. This demonstrates that 1) Precision is required for restoration of vaginal tension. 2) Such precision may not be entirely achievable using our present techniques. 3) Therefore, as an alternative, in order to achieve this precision, we advise, in all operations, that further adjustment of the vagina may be necessary in up to 20% of patients. *Disadvantage of this procedure.* Rejection may lead to scarring and worsening of symptoms.

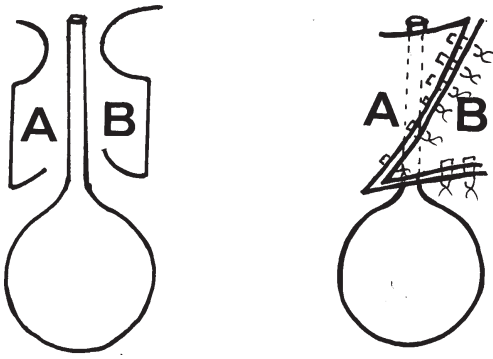

FIG2

**Z-plasty for restoration of laxity to ZCE**

The flaps A & B are mobilized. A is swung across the urethra, and B is swung down towards the bladder neck area of vagina.

*Alternative procedure.* If there is also an obvious suburethral laxity, then a simple z-plasty FIG2 may give good results (unpublished data), as it simultaneously tightens the suburethral vagina, and loosens the excessive tightness of vagina in the bladder neck area over the ensuing 6 weeks. This technique uses the process of “visco-elastic creep” to advantage. If there is also a net deficit of vaginal tissue in the anterior vaginal wall, combining the z-plasty FIG2 with say, a vulval flap to cover any bareness created in the suburethral vagina may create sufficient laxity in the “zone of critical elasticity” to restore the separate closure mechanisms.

**CORRESPONDENCE:**

P.E.PAPA PETROS  
14A/38 Ranelagh Crescent  
South Perth WA 6151  
Australia  
Fax: 61-9-474 3766

**REFERENCE**

Petros P & Ulmsten U. The tethered vagina syndrome, postsurgical incontinence and I-plasty operation for cure. *Acta Obstet et Gynecol Scand.* 1990; Suppl. No 153, 69:63-67.





# THE POSTERIOR FORNIX SYNDROME: A MULTIPLE SYMPTOM COMPLEX OF PELVIC PAIN AND ABNORMAL URINARY SYMPTOMS DERIVING FROM LAXITY IN THE POSTERIOR FORNIX OF VAGINA.

Short title: Posterior fornix syndrome. Key words: Pelvic pain, dyspareunia, “obstructed “ flow , urge incontinence, stress incontinence, residual urine, hysterectomy.

Authors:

PE PAPA PETROS\* Dr Med Sc MRCOG FRACOG Dept of Gynaecology Royal Perth Hospital Perth, Western Australia, Dept of Obstetrics and Gynaecology Uppsala University Akademiska sjukhuset Uppsala, Sweden and

U Ulmsten, MDPHD Dept of Obstetrics and Gynaecology Uppsala University Akademiska sjukhuset Uppsala, Sweden

## ABSTRACT

The “posterior fornix syndrome”, as studied in 28 patients, is described. It consists of multiple symptoms of pelvic pain and abnormal urinary symptoms deriving from laxity in the posterior fornix of vagina. The symptoms encompassed include pelvic pain (32%), deep dyspareunia (39%), symptoms of stress (32%) and urge (39%) incontinence, those associated with defective bladder neck opening (35%), and high residual urine (52%). The percentage incidence of symptoms, as denoted by brackets was expressed as a percentage of 28, and were only attributed to this syndrome if they abated after surgical cure. A simple posterior fornix repair performed under local anaesthesia cured more than 50% of the symptoms in each category, indicating that laxity in the posterior vaginal fornix was most likely the prime cause of these symptoms.

## INTRODUCTION

The role of the uterosacral ligaments and posterior wall of vagina has received scant attention as concerns their pathogenesis in pelvic pain and female incontinence. Cure of symptoms including collision dyspareunia, low abdominal pain, low sacral backache, and urge symptoms by laparoscopic ventrosuspension and hysterectomy has been reported previously (1).

In a preliminary report, we confirmed (2) that not only urge, but also stress symptoms could be caused by laxity in the uterosacral ligaments, and that both were frequently curable by a simple posterior fornix repair. The theory predicted that such vaginal laxity may also be a cause of high residual urine, and symptoms of defective bladder neck opening (3). (Relevant symptoms are detailed in Appendix A). The aim of this study was to test previous findings (1)(2), and to further investigate clinical and urodynamic manifestations of laxity in the posterior vaginal fornix.

## PATIENTS, MATERIALS AND METHODS

Twenty-eight patients were studied. Mean age was 45 years (range 32-71) parity 2.7 (range 0-6). Inclusion criteria were based on having either low pelvic pain or collision dyspareunia not of inflammatory origin, Appendix A, a residual urine of more than 50 mls in patients without previous incontinence surgery, or more than one symptom of defective bladder neck opening as detailed in Appendix A.

The patients arrived for testing with a comfortably full bladder. Objective testing included special exercise pad tests, Urine loss, if any, was measured during provocation with 10 coughs and 10 star jumps. Urethrocytometric testing was performed according to (4) and included pressure transmission ratios (PTR) during coughing, straining, and "cutting-off" in the supine position, and a hand-washing test for urge incontinence and bladder instability performed in the standing position. Urinary flow studies, bladder volume, and residual urine estimations were also performed. A pessary was inserted as described (1) in 50% of the patients.

**Operation.** The posterior fornix repair was performed entirely under local anaesthesia, often as an office procedure. The patient was placed in the lithotomy position. The corners of the posterior fornix were gently grasped by Littlewood's forceps without applying pressure. Using long needle, preferably with a shield over the point (e.g Cobak), the vaginal mucosa was infiltrated with 5-10 mls of 0.5-1% xylocaine with 1/200,000 adrenalin on each side extending to the midline, grasped firmly with Littlewood's forceps, and pulled laterally and forwards. Under tension, a full thickness horizontal incision was made with a scalpel between the forceps. The points of long-handled scissors were inserted antero-posteriorly in the incision, and the handles opened out, i.e. the scissor points stretched open the incision in an antero-posterior plane. If possible, the uterosacral ligaments were identified, approximated in the midline, followed down posteriorly and further approximated. No1 Vicryl was used, and the needle point frequently used to locate the often deeply set ligaments. The vaginal mucosa was then approximated from side to side. Care was taken to approximate the tissues without excessive tension. If an enterocele or high rectocele were present, they were appropriately repaired at the same time in the surgical theatre.

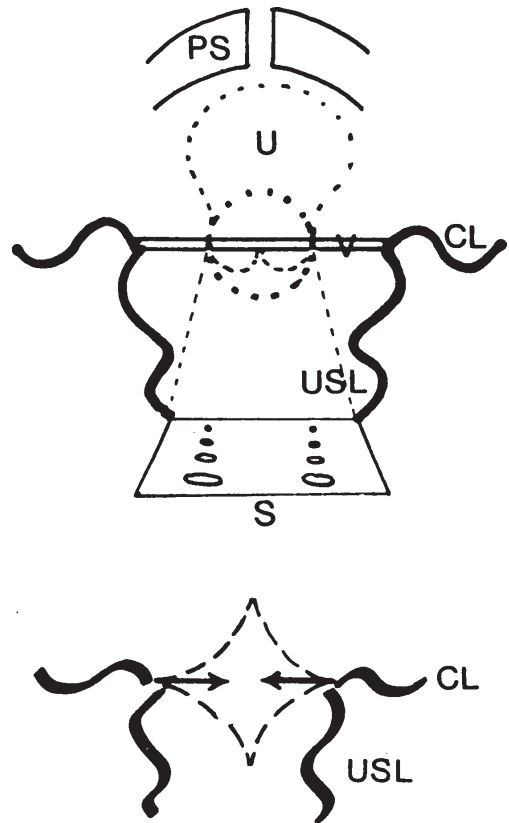

**FIG 1**  
**How hysterectomy may create a posterior fornix defect.**

This is a schematic view of the pelvis as seen from above. PS = pubic symphysis; USL = uterosacral ligament; CL = cardinal ligament; V = vagina; S = sacrum; U = uterus; in the upper diagram, the broken lines indicate the pre-operative state the solid lines indicate how suturing the vault horizontally loosens it's ligamentous support from CL and USL; in the lower diagram, the arrows indicate how CL and USL may be tightened by suturing a horizontal posterior fornix incision from side to side.

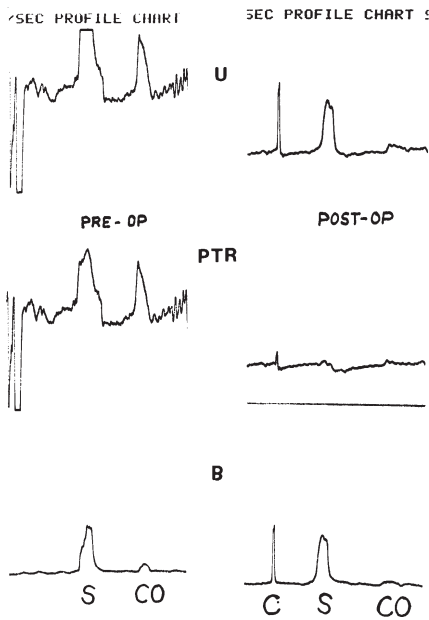

**FIG 2**  
**Conversion of pressure transmission ratio after posterior fornix repair.**  
 This is a pressure transmission graph of the same patient with readings taken immediately before and after a posterior fornix repair. U = urethral channel; PTR = subtractor channel; B = bladder channel; S = strain; C = cough; CO = cut-off.

*Postoperative assessment.* The postoperative assessment was performed by a third person, trained in female incontinence, and using the questionnaire, Appendix A, personal interview, and objective testing as above. The results were entered onto a data base, and subsequently analysed. No patients were lost from the study. The symptoms were only attributed to this syndrome if they abated after surgical cure, Tables I & III.

**RESULTS**

The postoperative assessment was performed between 4 and 30 months postoperatively (mean 12 months). The results are summarized in tables I, II & III. In 19 patients, mean residual urine was reduced from 123 mls preoperatively (range 500 mls to 2 mls) to 31 mls postoperatively (range 150 mls to 0 mls). The peak flow was virtually unaltered, 30 mls/sec. postoperatively, as against 28 mls/sec preoperatively.

In 7 patients with a positive Valsalva pressure transmission ratio (PTR) and symptoms of urinary incontinence, the Valsalva PTR was repeated immediately after the procedure had been performed under local anaesthesia. All 7 readings converted from positive to neutral or slightly negative, FIG 2. We confirmed that symptoms, including high residual urine, may be greatly improved after pessary insertion. TABLE I (28 Patients)

symptom	cured	improved	true frequency of symptoms*
stress incontinence n = 19	9	4	32%
urge incontinence n = 21	11	3	39%
defective opening n = 16	10	-	35%
low pelvic pain n = 12	9	-	32%
deep dyspareunia n = 16	11	-	39%
residual urine n=19	10	-	53%

\* Symptoms were expressed as a percentage of 28 and only attributed as part of the posterior fornix syndrome if cured.

**TABLE II - VALSALVA PTR**

	Positive	Negative
stress incontinence n = 19	12	7
urge incontinence n = 21	13	8

TABLE III  
(14 HYSTERECTOMY PATIENTS)

symptom	cured	improved	failed
stress incontinence n = 9	6	3	0
urge incontinence n = 13	8	2	3
defective opening n = 8	6	-	2
low pelvic pain n = 7	5	-	2
deep dyspareunia n = 7	4	-	3

## DISCUSSION

*Clinical diagnosis.* The patient may have pelvic pain (cf "pelvic pain syndrome" (1), Appendix A), urgency (1), and varices noted laparoscopically at the site of the uterosacral ligaments (1). *We found that symptoms of stress incontinence, defective opening and findings of high residual urine, are also an important part of the syndrome.* As these symptoms may occur after (indeed be caused by) hysterectomy, we consider that the "posterior fornix syndrome" may be an appropriate term. The high correlation between symptoms of incontinence and a positive Valsalva pressure transmission test is a promising objective test. On examination there may be a bulge between the uterosacral ligaments, or presence of an early enterocele. Insertion of a ring pessary may tighten the posterior fornix by stretching the supralelevator vagina (we have demonstrated this radiologically) and bring a dramatic improvement in symptoms\*. As such the pessary is a useful, but not infallible, predictive diagnostic test.

\* If the pessary used is too large, pelvic pain and worsening of symptoms may result. If it is too small there may be little or no improvement in symptoms. (Unpublished to date)

*Relationship of symptoms to hysterectomy and lax uterosacral ligaments.* In a prospective study involving 36 patients, some with urinary symptoms, Parys et al (5) reported an almost 100% increase in symptoms of defective emptying, (Appendix A), almost a 50% increase in symptoms of frequency, urgency and nocturia as well as a 20% increase in symptoms of

incontinence following hysterectomy. Langer et al (6) investigating a group of 16 women without urinary symptoms undergoing hysterectomy, found that hysterectomy did not cause symptoms of incontinence. We were able to substantially reverse a high proportion of symptoms, Table III with a posterior fornix repair, indicating that laxity in the posterior fornix may have been the ultimate cause of these symptoms. Such a reversal of symptoms would not be possible if partial denervation (7) of the pelvic floor was the principal causative factor for urinary incontinence.

*Pelvic pain.* Traction of a retroverted uterus on the sensory nerve endings of the posterior pelvic wall has been cited as an etiological factor for pelvic pain (8). We confirmed previous observations (1), (2) that laxity in the uterosacral ligaments may cause pelvic pain and dyspareunia. Though a large proportion of the patients' symptoms were previously cured with hysterectomy (1), we found persistence of pelvic pain and dyspareunia in many patients who had undergone hysterectomy. Many reported improvement after posterior fornix repair, Table III. *We conclude from the above that if pelvic pain can be caused by hysterectomy, it cannot be the hysterectomy per se which cures the pelvic pain, but the concomitant surgical repair of the ligamentous supports of the posterior vaginal fornix performed at the time of the hysterectomy.*

*Pathogenesis.* Anatomically, any looseness in the vagina between the pubourethral ligament, and the uterosacral ligament may cause symptoms (3). Overdistension of the posterior fornix during labour, or transverse suturing of the vault during hysterectomy are hypothesized as being principal etiological factors (2), though we have seen it in a nulliparous patient, becoming symptomatic after menarche. Laxity of the supralelevator vagina may not allow adequate tensioning of the vagina below the bladder neck nerve endings. This lack of underlying support may cause the nerve endings to fire off, prematurely activating the micturition reflex, resulting in symptoms of frequency, urgency nocturia.

*Some surgical considerations.* Though effective (1), we do not agree, on anatomical grounds, that laparoscopic ventrosuspension (1) is the appropriate treatment. This operation works by elevating the uterus via the round ligaments, which are not structural entities. Also, elevation may create a potential enterocele space. Elevation of the uterus may cause frequency and urgency on its own account (9). The process of bladder neck opening requires that there be no laxity between anterior wall of rectum and posterior wall of vagina, i.e. a high rectocele, if present, also needs to be corrected, along with any enterocele, or laxity in the uterosacral ligaments.

#### **CORRESPONDENCE:**

P.E.PAPA PETROS  
14A/38 Ranelagh Crescent  
South Perth WA 6151  
Australia  
Fax: 61-9-474 3766

#### **REFERENCES**

- (1) Hastwell GB. Psychogenic pelvic pain or the Occult Prolapse Syndrome. *Medical Journal of Australia.* (1986),144:405-407.
- (2) Petros P and Ulmsten U. The role of a lax posterior vaginal fornix in the causation of stress and urgency symptoms: a preliminary report. *Acta Obstetrica et Gynaecologica Scandinavica* 69, Suppl. 153, 71-73, 1990.
- (3) Petros P and Ulmsten U. An integral theory of female urinary incontinence. *Acta Obstetrica et Gynaecologica Scandinavica* 69, Suppl. 153, 1-79, 1990.
- (4) Ulmsten U, Asmussen M and Lindstrom K. A new technique for simultaneous uethrocystometry and measurements of the urethral pressure profile. *Urol Int.* (1977),32:88-92.
- (5) Parys BT, Haylen BT and Parsons KF. Urodynamic evaluation of lower urinary tract function in relation to total hysterectomy. *Aust. NZ J. Obstet. Gynaecol.* 30, 161-165, 1990.
- (6) Langer R, Neuman M, Ron-El R, Golan A, Bukovsky I and Caspi E. The effect of total abdominal hysterectomy on bladder function in asymptomatic women. *Obstet. Gynecol.* 74, 2, 205-207, 1989.
- (7) Smith A, Hosker G and Warrell D. Role of pudendal nerve damage in the aetiology of genuine stress incontinence in women. *Brit. J. Obstet. and Gynaecol.* 96, 29-32, 1989.
- (8) Martius H, as quoted by Nijs P. Psychological aspects of pelvic pain experience. P 24-37 in *Chronic Pelvic Pain in Women* Springer-Verlag Berlin ED Renner M, 1981.
- (9) Hodgkinson CP and Kelly WT. Urinary stress incontinence in the female 111. Round-ligament technic for retropubic suspension of the urethra, *Obstet. Gynecol.* 10:5, 493-499, 1957.